

City and County of Denver  
**Small Cell Infrastructure  
Design Guidelines**



Department of Public Works  
Engineering Division

April 2018



## Developed by:



The City and County of Denver  
Public Works Department

Jon Reynolds, Engineering Supervisor



Jacobs Engineering Group

Mike Butters, Project Manger

**CLANTON & ASSOCIATES**



**Clanton & Associates:**

Nancy Clanton, CEO

Dane Sanders, Principal

Annie Kuczkowski, Engineer II - Lighting



**Aero Wireless Group:**

Jim Lockwood, CEO

Mike Hoganson, Chief Operating Officer

## Contributions:

Cover Image: Photo courtesy of Aero Wireless Group

# Contents

1	Background and Purpose.....	1
1.1	Type 1 Attachments to Utility Poles .....	2
1.2	Type 2 Small Cell on Existing Wooden Pole with Streetlight .....	3
1.3	Type 3 Combination Small Cell and Streetlight.....	4
1.4	Type 4 Freestanding Small Cell.....	7
2	Attachments to Utility Poles and Utility Lines .....	9
2.1	Purpose.....	9
2.2	General Guidance.....	9
2.3	Utility Pole Small Cell Attachments Specification Overview .....	10
2.4	Strand Mounted Small Cell Attachments Specification Overview .....	12
2.5	Small Cell Attachments to Utility Poles and Utility Lines Placement Requirements.....	13
3	Attachments to Wooden Streetlight Poles.....	15
3.1	Purpose.....	15
3.2	General Guidance.....	15
3.3	Wooden Streetlight with Small Cell Specification Overview.....	16
3.4	Wooden Streetlight with Small Cell Placement Requirements.....	17
4	Combination Small Cell and Streetlight .....	19
4.1	Purpose.....	19
4.2	General Guidance.....	19
4.3	Basis of Design.....	19
4.3.1	Type 3A Combination Pole .....	21
4.3.2	Type 3B Combination Pole.....	22
4.3.3	Type 3C Combination Pole .....	23
4.4	Combination Small Cell and Streetlight Specification Overview.....	24
4.5	Placement Requirements.....	27
5	Freestanding Small Cell Infrastructure .....	29
5.1	Purpose.....	29
5.2	General Guidance.....	29
5.3	Basis of Design.....	29
5.4	Freestanding Small Cell Specification Overview.....	32
5.5	Placement Requirements.....	33
	Appendix A: Details.....	A-1
	Appendix B: Specifications.....	B-1
	Appendix C: Small Cell Infrastructure in Denver.....	C-1

## List of Figures

Figure 1-1: Unique streetlight assembly .....	1
Figure 1-2: Type 1B - Strand Mounted Shroud.....	2
Figure 1-3: Type 1A - Utility Pole Mounted Shroud.....	2
Figure 1-4: Type 2 - Attachment to Wooden Streetlight Pole .....	3
Figure 1-5: Type 3A - Combination Pole with Cantenna .....	4
Figure 1-6: Type 3B - Combination Pole with Shroud .....	5
Figure 1-7: Type 3C - Combination Pole with Cantenna and Equipment Shroud .....	6
Figure 1-8: Type 4 - Freestanding Small Cell .....	7
Figure 2-1: Utility Pole Attachment.....	10
Figure 2-2: Strand Mounted Attachment.....	12
Figure 3-1: Attachment to Wooden Streetlight Pole .....	15
Figure 4-1: Unacceptable Type 3 Installation.....	20
Figure 4-2: Acceptable Type 3 Installation .....	20
Figure 4-3: Type 3A - Combination Pole with Cantenna .....	21
Figure 4-4: Type 3B - Combination Pole with Equipment Shroud .....	22
Figure 4-5: Type 3C - Combination Pole with Cantenna and Equipment Shroud .....	23
Figure 5-1: Freestanding Small Cell Pole.....	29
Figure 5-2: Unacceptable Type 4 Installation.....	30
Figure 5-3: Acceptable Type 4 Installation .....	30
Figure 5-4: Freestanding Small Cell Assembly .....	31
Figure 5-5: Freestanding Small Cell spacing radius.....	34
Figure 5-6: Freestanding small cell in amenity zone.....	35
Figure 5-7: Standalone Small Cell sight-line requirements .....	35
Figure 5-8: Freestanding small cell location between property and trees.....	36
Figure 5-9: Freestanding Small Cell between property lines .....	36
Figure 5-10: Small Cell in Commercial Area.....	37

## List of Tables

Table 2-1: Small Cell Attachments to Utility Pole Specification Overview .....	11
Table 2-2: Small Cell Attachments to Utility Pole and Utility Lines Specification Overview .....	13
Table 3-1: Wooden Streetlight Attachments Specification Overview .....	16
Table 4-1: Streetlight Specification Overview .....	24
Table 4-2: Equipment Cabinet Specification Overview .....	25
Table 4-3: Upper Pole Specification Overview .....	26
Table 4-4: Cantenna Specification Overview .....	26
Table 5-1: Freestanding Small Cell Infrastructure Specification Overview .....	32



## BACKGROUND AND PURPOSE

### 1 BACKGROUND AND PURPOSE

Numerous wireless providers and wireless infrastructure companies have been contacting the City and County of Denver with requests to locate small cell facilities in the public right of way (ROW). These low-powered antennas provide cellular and data coverage to supplement the provider's cellular network. New small cell towers will improve the providers ability to meet current and future cellular needs.

These *Small Cell Design Guidelines* provide aesthetic requirements and specifications that all small cell towers installed within the public ROW must meet prior to installation in the City and County of Denver (CCD). Small cells not installed within the public ROW are not bound to the requirements of this guide; although, the public ROW small cell guidelines may inform these installations.

Network Providers shall consider the aesthetics of the existing streetlights and neighborhoods adjacent to proposed small cell locations prior to submitting an application to CCD. New small cells shall match the existing streetlight aesthetics when installed in a Special District or neighborhood with unique streetlight assemblies. Unique assemblies may include mast arms, decorative pole bases, architectural luminaires, mounting heights, pole colors, etc. that deviate from these guidelines. An example of a unique streetlight can be found in Figure 1-1. CCD must approve all small cell installations that deviate from these guidelines.

Four different types of small cell installations are permitted within CCD. These types include attachments to utility poles and utility lines, attachments to wooden utility poles, removal and replacement of existing streetlights, and new freestanding installations. An overview of each type is shown in Sections 1.1 through 1.4.

Deviations from this Guide shall be approved by CCD prior to installation.

The purpose of this document is to establish guidelines for installing small cell equipment and poles in the City and County of Denver's right of way.

Figure 1-1: Unique streetlight assembly

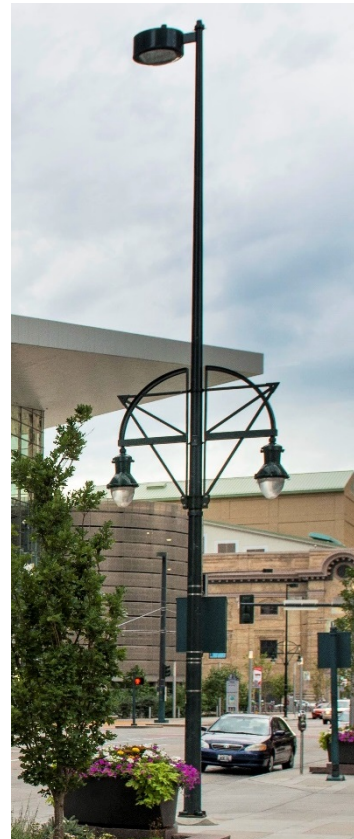

Image courtesy of Robb Williamson

## 1.1 Type 1 Attachments to Utility Poles

The Attachments to Utility Poles chapter establishes the specification requirements and design guidelines for small cell equipment that will be attached to existing wooden utility poles located in the CCD's Right of Way.

Figure 1-2 and Figure 1-3 below show both a pole mounted enclosure and strand mounted enclosure.

Figure 1-2: Type 1B - Strand Mounted Shroud

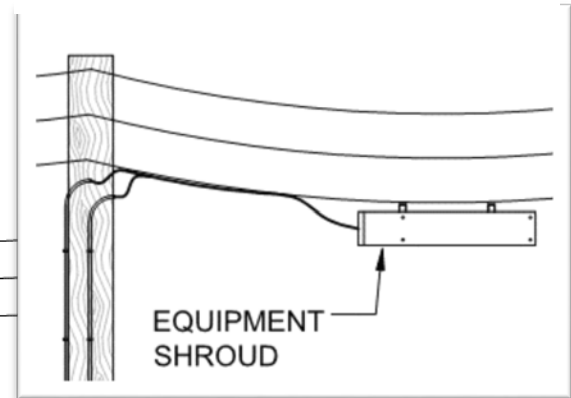
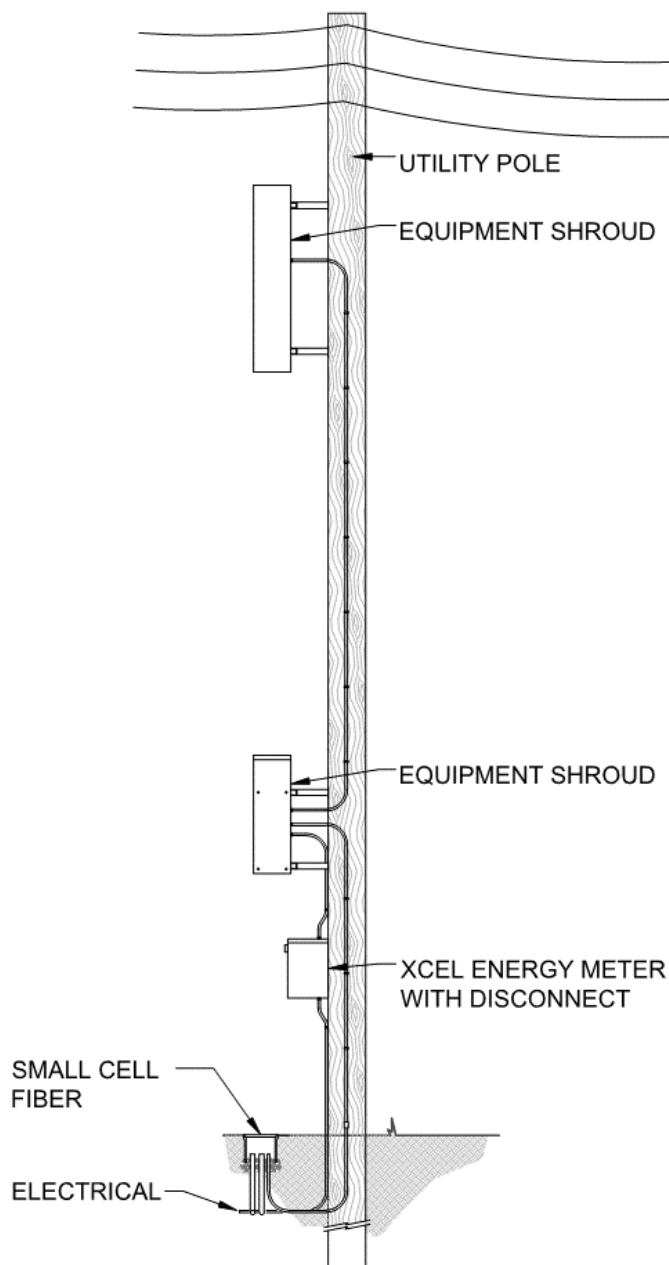

Figure 1-3: Type 1A - Utility Pole Mounted Shroud





## 1.2 Type 2 Small Cell on Existing Wooden Pole with Streetlight

The Attachments to Wooden Streetlight Pole chapter establishes the specification requirements and design guidelines for small cell equipment that will be attached to existing wooden streetlight poles within the public ROW.

Figure 1-4: Type 2 - Attachment to Wooden Streetlight Pole

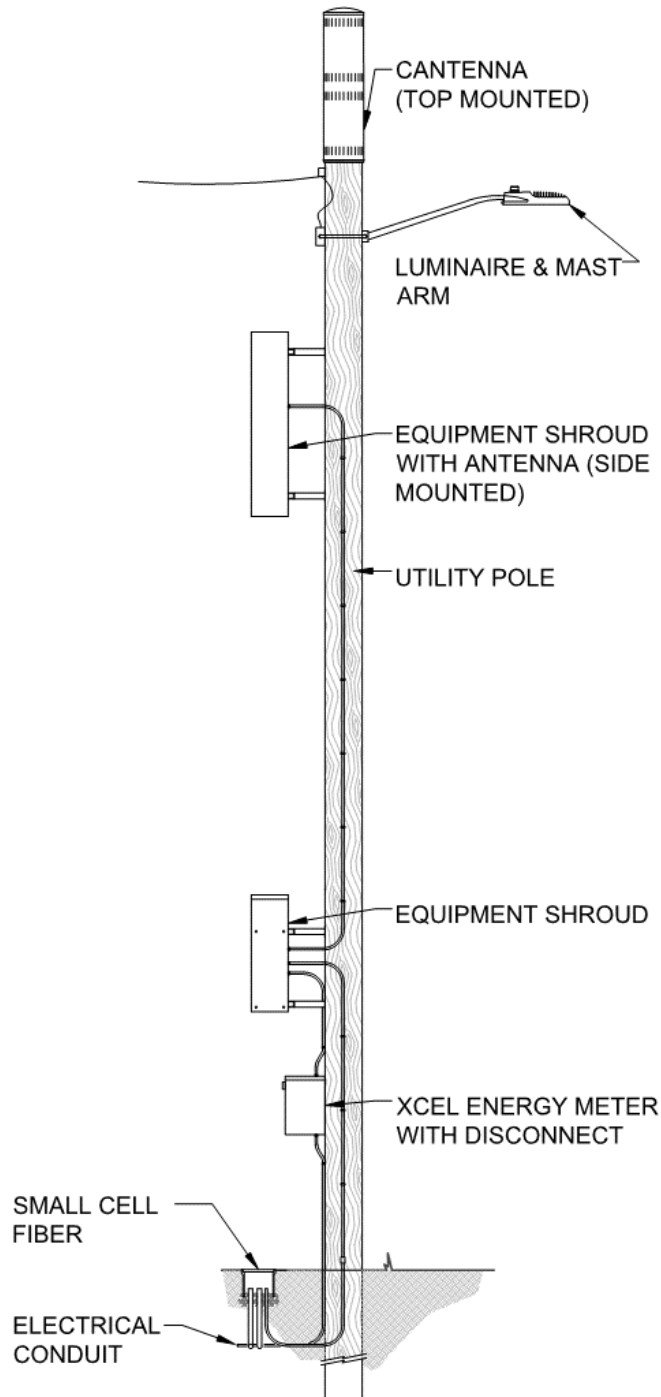

### 1.3 Type 3 Combination Small Cell and Streetlight

The Combination Small Cell and Streetlight Assembly chapter establishes requirements when removing existing metal streetlight poles in the public ROW and replacing with combination small cell and streetlight poles. Three variations of the combination pole are shown in Figure 1-5 through Figure 1-7. Only one carrier may be installed per pole.

Small Cell Type 3A, shown in Figure 1-5, is intended for a single carrier installation. This pole type includes a cantenna and no externally mounted equipment.

Figure 1-5: Type 3A - Combination Pole with Cantenna

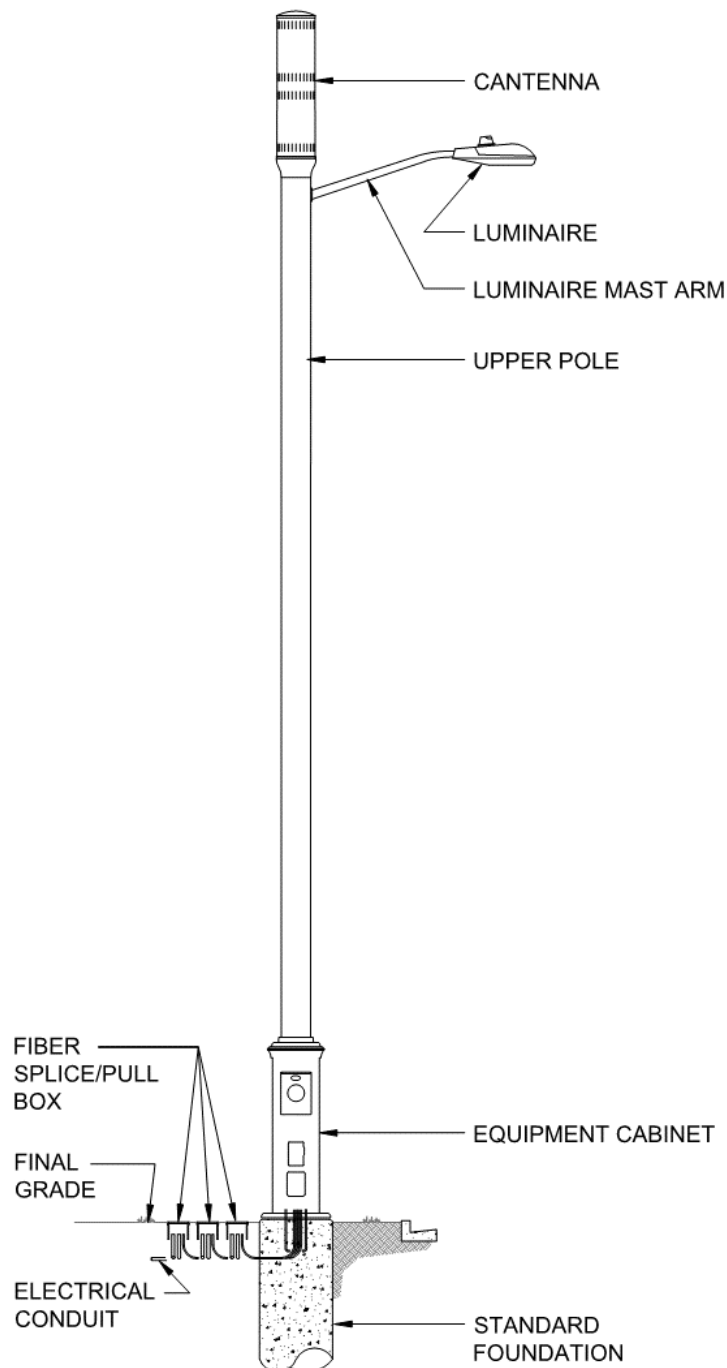

A Type 3 combination pole with a single external shroud mounted to the pole will be allowed in place of a cantenna. The shroud shall be strapped to the pole in such a way that the wiring, cables, and equipment is be hidden from view. The shroud shall be colored to match the pole.

Figure 1-6: Type 3B - Combination Pole with Equipment Shroud

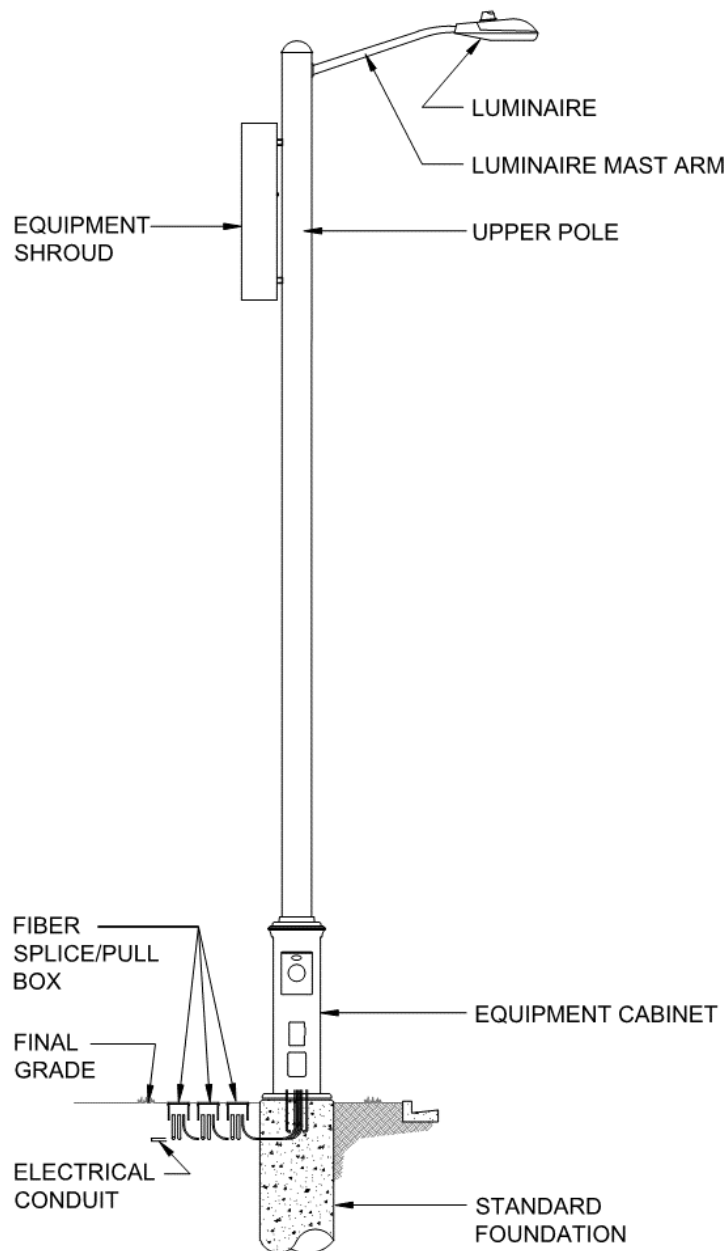

A Type 3 combination pole with both a cantenna and a single shroud mounted to the pole is allowed when various small cell technologies (ie: LTE and 5G) provided by a single carrier are installed on the same pole. The shroud shall be strapped to the pole in such a way that the wiring, cables, and equipment is be hidden from view. The cantenna and shroud shall be colored to match the pole.

Figure 1-7: Type 3C - Combination Pole with Cantenna and Equipment Shroud

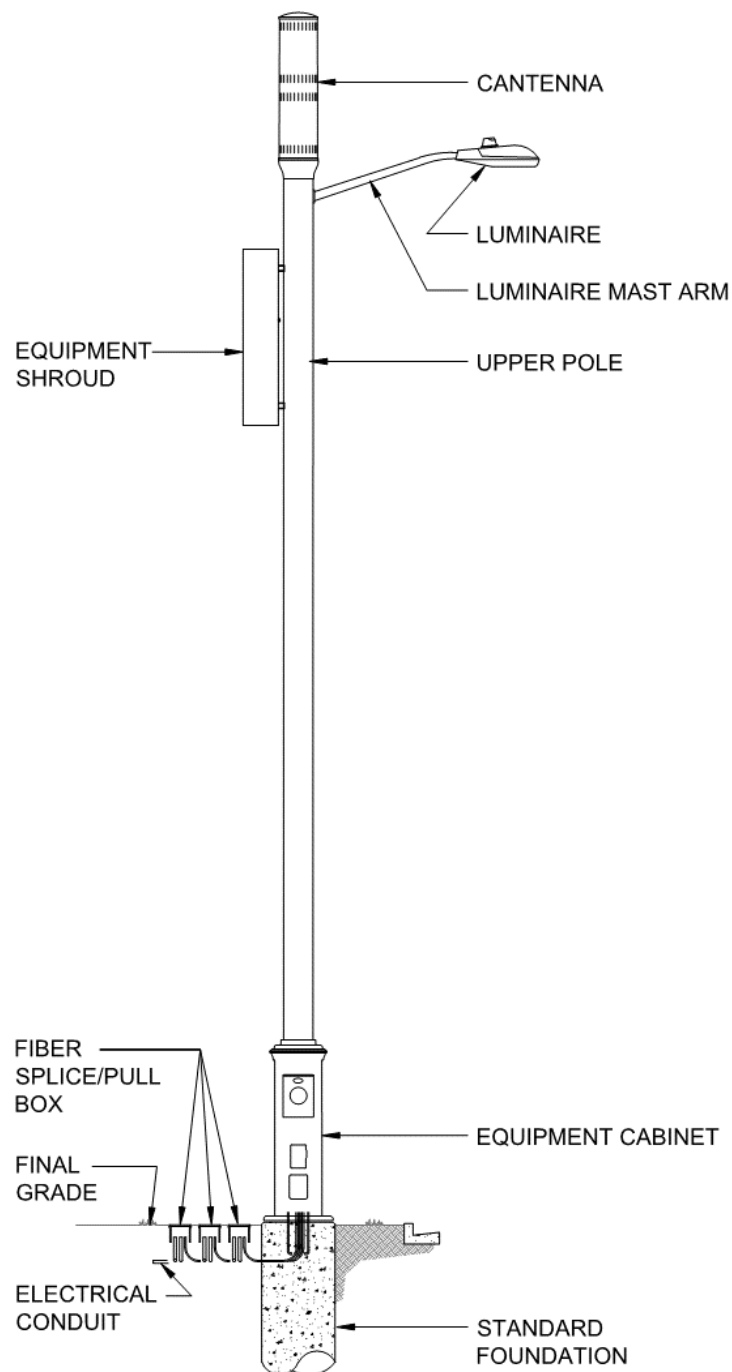

## 1.4 Type 4 Freestanding Small Cell

The Freestanding Small Cell chapter establishes specification requirements and design guidelines for installing privately-owned freestanding small cell poles in the public ROW.

Figure 1-8: Type 4 - Freestanding Small Cell

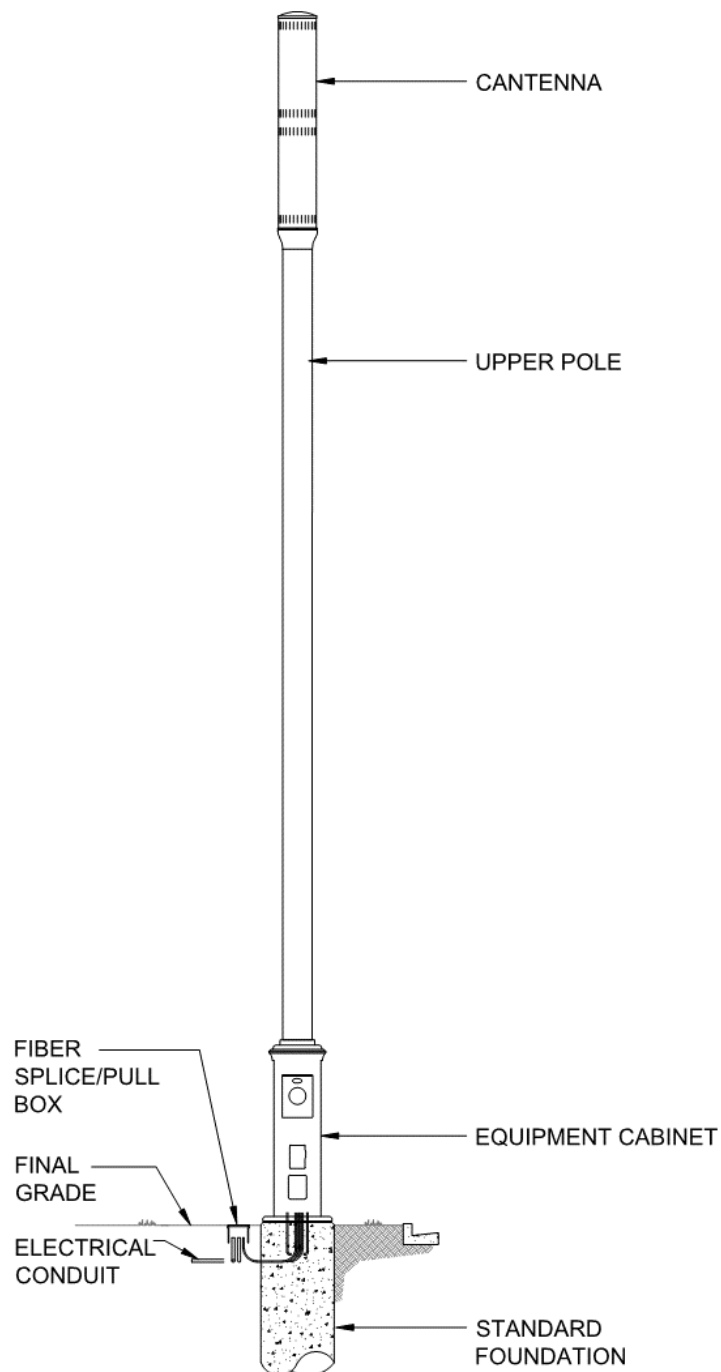

[This page intentionally left blank]



## 2 ATTACHMENTS TO UTILITY POLES AND UTILITY LINES

### 2.1 Purpose

This chapter of the Guide is to be used when locating small cell attachments on existing utility poles or utility lines. Refer to Chapter 3 for projects involving existing wooden streetlight small cell attachments.

### 2.2 General Guidance

All attachments to utility poles shall be approved by CCD and Xcel Energy prior to installation. All equipment shall meet Xcel Energy's utility requirements and CCD's *Freestanding Small Cell Infrastructure ROW Permit Entrance Requirements*.

All small cell carrier equipment shall be shrouded. Only two enclosures including the disconnect and antenna shall be installed at each utility pole location. No ground mounted enclosures, including backup power supply, shall be allowed. All equipment located within the public ROW shall be located such that it meets ADA requirements and does not obstruct, impede, or hinder usual pedestrian or vehicular travel.

All carrier equipment shall be removed and relocated at no cost to CCD if CCD or Xcel Energy decides to underground the utility lines in the future. The equipment must be removed within a reasonable time frame determined by Xcel Energy. A reasonable time frame refers to a period of time that does not delay the removal of the utility poles and lines.

No strand-mounted small cell devices shall be installed on poles with mounted streetlights. Deviations from this guide shall be approved on a case-by-case basis by CCD prior to installation.

Refer to Chapter 2 for information regarding small cell equipment that will be attached to existing utility poles and utility lines.

## 2.3 Utility Pole Small Cell Attachments Specification Overview

Prior to submitting a permitting application, the pole owner shall ensure the supporting poles are appropriately sized and have sufficient strength to accommodate the additional small cell equipment loads. The small cell equipment loads shall be provided by the network provider.

A non-ionizing radiation electromagnetic radiation report (NIER) shall be submitted to the pole owner and retained on file for equipment type and model. The NIER report shall be endorsed by an RF PE licensed in the State of Colorado. It shall specify minimum approach distances to the general public as well as electrical and communication works that are not trained for working in an RF environment (uncontrolled) when accessing the pole by climbing or bucket.

All installations shall meet or exceed all applicable structural standards, clearance standards, and provisions of the latest National Electrical Safety Code (NESC), or applicable CCD construction standards. In case of conflict, the most stringent requirements shall prevail. All necessary permits shall be obtained by the wireless carrier owner and provided to the pole owner and CCD.

Figure 2-1: Utility Pole Attachment

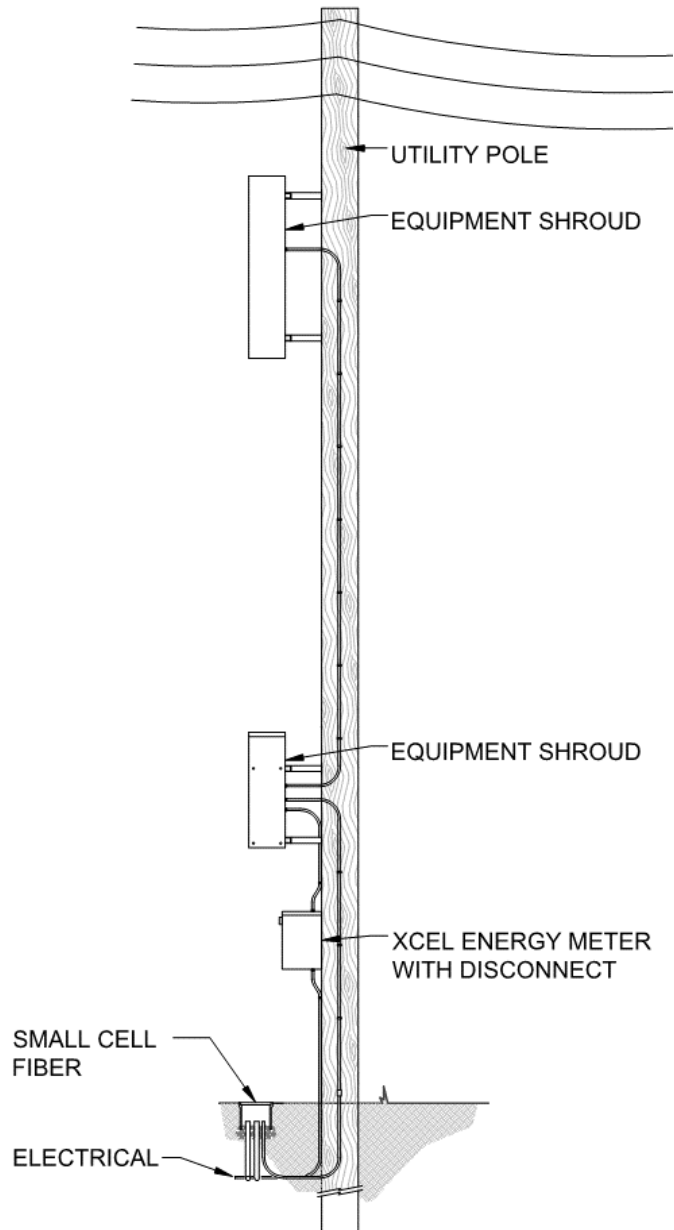



**Table 2-1: Small Cell Attachments to Utility Pole Specification Overview**

Utility Pole and Strand Mount Specification Overview	
<b>Electrical Service</b>	Per Xcel Energy
<b>Grounding</b>	Per Xcel Energy’s requirements.
<b>Separation of Service</b>	All new electrical conduit and fiber shall be separated by Owner
<b>Utility Equipment</b>	Per Xcel Energy
<b>Equipment Color</b>	Visible attachments and hardware shall be colored to match pole, or colored gray (7047) if located on a wooden pole.
<b>Equipment Shroud</b>	<p>38”H x 16”W x 12”D maximum</p> <p>Only one equipment shroud, containing all required small cell equipment, shall be installed per pole. Except, one additional equipment shroud shall be allowed per pole if the antenna is located within the second equipment shroud.</p> <p>Equipment shall be located such that it meets the Americans with Disabilities Act of 1990 and does not obstruct, impede, or hinder the usual pedestrian or vehicular travel way.</p>
<b>Cantenna</b>	<p>If a cantenna is located on top of the pole the outer diameter shall be 14” maximum and the cantenna shall be no more than 5 feet tall, including antenna, radio head, mounting bracket, and all other hardware necessary for a complete installation.</p> <p>If the cantenna is mounted to the side of the pole it shall be located inside a shroud of 5.5 cubic feet maximum. The width, depth, or diameter of the shroud size shall not be greater than 16” (maximum).</p>
<b>RF Equipment Disconnect</b>	Radio frequency equipment shall have a disconnect that meets or exceeds Xcel Energy’s requirements.
<b>Pole Mounted Warning Label</b>	If required, radio frequency warning labels shall be mounted exterior to Carrier’s equipment.
<b>Strand Mounted Warning Label</b>	Radio frequency warning labels shall be mounted on the equipment, and clearly mark both sides of the enclosure and be visible from the ground, roadside, and field side.
<b>Owner Identification</b>	A 4-inch by 6-inch (maximum) plate with the Carrier’s name, location identifying information, and emergency telephone number shall be permanently fixed to the shroud.

## 2.4 Strand Mounted Small Cell Attachments Specification Overview

Prior to submitting a permitting application, the strand owner shall ensure the supporting poles are appropriately sized and have sufficient strength to accommodate the additional equipment loads.

A non-ionizing radiation electromagnetic radiation report (NIER) shall be submitted to the pole owner and retained on file for equipment type and model. The NIER report shall be endorsed by an RF PE licensed in the State of Colorado. It shall specify minimum approach distances to the general public as well as electrical and communication workers that are not trained for working in an RF environment (uncontrolled) when accessing the pole by climbing or bucket.

All installations shall meet or exceed all applicable structural standards, clearance standards, and provisions of the latest NESC or applicable CCD construction standards. In case of conflict, the most stringent requirements shall prevail. All necessary permits shall be obtained by the wireless carrier owner and provided to the utility owner and CCD.

Aerial fiber and power strand installations are allowed even though Figure 2-2 shows an example of an undergrounded fiber and power installation.

Figure 2-2: Strand Mounted Attachment

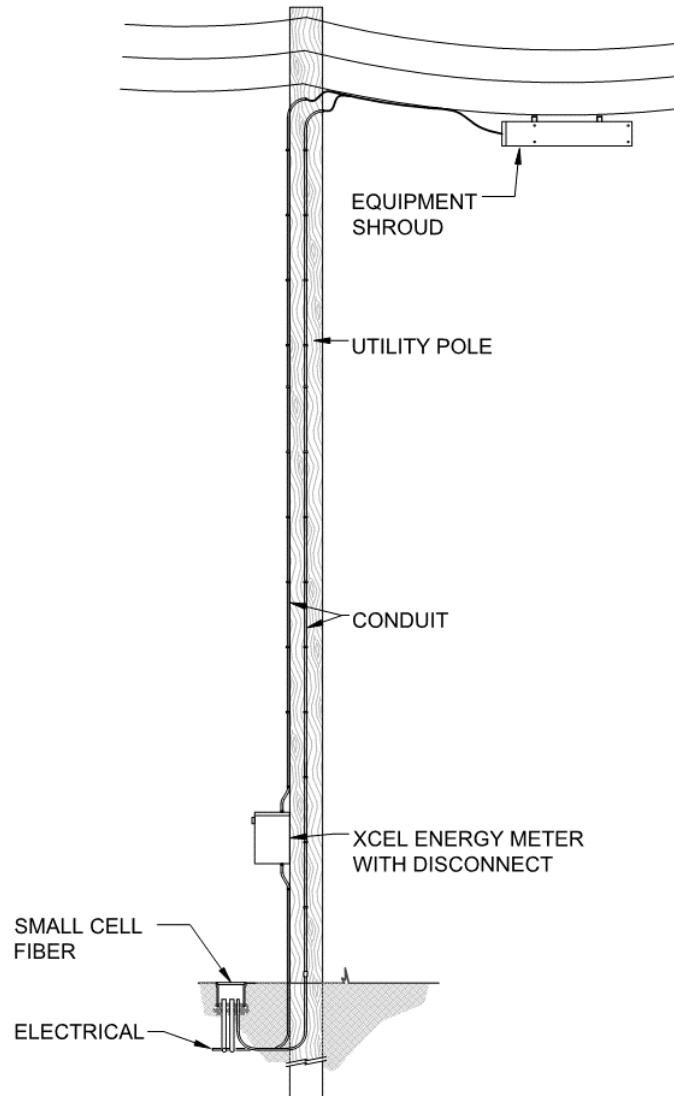

**Table 2-2: Small Cell Attachments to Utility Pole and Utility Lines Specification Overview**

<b>Utility Pole and Strand Mount Specification Overview</b>	
<b>Electrical Service</b>	Per Xcel Energy
<b>Grounding</b>	Per Xcel Energy’s requirements.
<b>Separation of Service</b>	All new electrical conduit and fiber shall be separated by Owner
<b>Utility Equipment</b>	Per Xcel Energy
<b>Equipment Color</b>	Visible attachments and hardware shall be colored gray (RAL 7047)
<b>Strand Mount Equipment Shroud</b>	5.5 cubic feet maximum strand mount equipment shroud. Only one equipment shroud shall be installed per permit location.
<b>RF Equipment Disconnect</b>	Radio frequency equipment shall have a disconnect that meets or exceeds Xcel Energy’s requirements.
<b>Pole Mounted Warning Label</b>	If required, radio frequency warning labels shall be mounted exterior to Carrier’s equipment.
<b>Strand Mounted Warning Label</b>	Radio frequency warning labels shall be mounted on the equipment, and clearly mark both sides of the enclosure and be visible from the ground, roadside, and field side.
<b>Owner Identification</b>	A 4-inch by 6-inch (maximum) plate with the Carrier’s name, location identifying information, and emergency telephone number shall be permanently fixed to the shroud.

## 2.5 Small Cell Attachments to Utility Poles and Utility Lines Placement Requirements

Small cell shall be located such that all new equipment, including but not limited to Network Provider small cell equipment and Xcel Energy equipment, meets ADA requirements. Xcel Energy, and CCD when applicable, shall approval all fiber and power source locations prior to installation.

[This page intentionally left blank]

Chapter

3

ATTACHMENTS TO WOODEN STREETLIGHT POLES



### 3 ATTACHMENTS TO WOODEN STREETLIGHT POLES

#### 3.1 Purpose

This chapter of the Guide is to be used when locating small cell equipment on existing wooden streetlights.

If an existing wooden streetlight pole, that small cell equipment is proposed upon, requires replacement it shall be required to replace said pole with a Type 3 installation.

#### 3.2 General Guidance

All attachments to wooden streetlights shall be approved by CCD and Xcel Energy prior to installation. All equipment shall meet Xcel Energy's utility requirements and the City and County of Denver's *Freestanding Small Cell Infrastructure ROW Permit Entrance Requirements*. All equipment located within the public ROW shall be located such that it meets ADA requirements and does not obstruct, impede, or hinder usual pedestrian or vehicular travel.

All small cell carrier equipment shall be mounted behind a shroud. Only two shrouds, including the disconnect and antenna, shall be installed at each location. No ground mounted equipment, including backup power supply, shall be allowed. No small cell devices shall be installed without confirming that the intended installation has no impact on the streetlight's operational performance.

The lighting design shall meet the luminaire specifications and design requirements set forth in the *City and County of Denver Street Lighting Design Guidelines*. These guidelines provide information about luminaire aesthetics, lighting criteria, typical streetlight spacing, specifications and details. The network provider shall provide all documentation required by the *Street Lighting Design Guidelines* to CCD during the permitting process.

All carrier equipment shall be removed and relocated at no cost to CCD if CCD or Xcel Energy decides to remove the wooden pole and streetlight in the future. The equipment must be removed within a

Refer to Chapter 3 for information about small cell equipment located in CCD's Right of Way and mounted to an existing wooden streetlight.

Figure 3-1: Attachment to Wooden Streetlight Pole

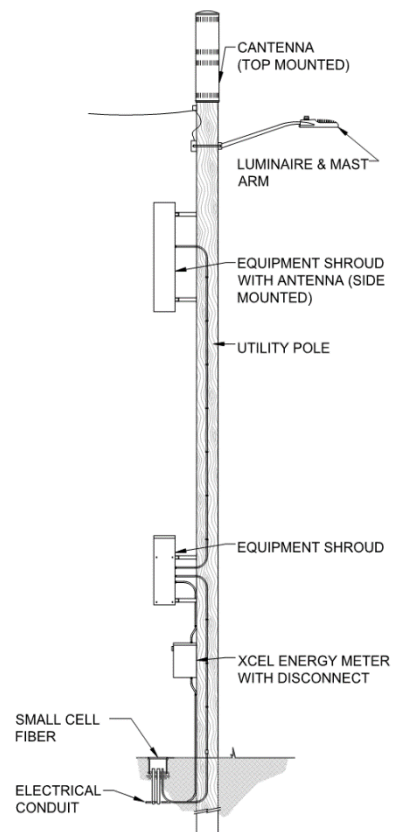

reasonable time frame determined by Xcel Energy. A reasonable time frame refers to a duration of time that does not delay the removal of the utility poles and lines.

Deviations from this guide shall be approved on a case-by-case basis by CCD prior to installation

### 3.3 Wooden Streetlight with Small Cell Specification Overview

Prior to submitting a permitting application, the Network Provider shall ensure the supporting poles are appropriately sized and have sufficient strength to accommodate the additional small cell equipment loads. All installations shall meet or exceed all applicable structural standards, clearance standards, and provisions of the latest NESC or CCD construction standards. In case of conflict, the most stringent requirements shall prevail. All necessary permits shall be obtained by the wireless carrier owner and provided to the pole owner and CCD.

A non-ionizing radiation electromagnetic radiation report (NIER) shall be submitted to the pole owner and retained on file for equipment type and model. The NIER report shall be endorsed by an RF PE licensed in the State of Colorado. It shall specify minimum approach distances to the general public as well as electrical and communication workers that are not trained for working in an RF environment (uncontrolled) when accessing the pole by climbing or bucket.

**Table 3-1: Wooden Streetlight Attachments Specification Overview**

General Specification Overview	
<b>Luminaire</b>	per <i>Denver Street Lighting Design Guidelines</i> .
<b>Luminaire Mast Arm</b>	Per Xcel Energy’s lighting standards
<b>Luminaire Mounting Height</b>	All luminaires shall be the same height as surrounding streetlights
<b>Electrical Service</b>	Per Xcel Energy’s requirements
<b>Grounding</b>	Per Xcel Energy’s requirements
<b>Separation of Service</b>	All new electrical conduit and fiber shall be separated by Owner, in pull/splice boxes located adjacent to the wooden streetlight pole.
<b>Utility Equipment</b>	Per Xcel Energy’s requirements
<b>Color</b>	Small cell equipment shall be colored gray (RAL 7074).
<b>Equipment Shroud</b>	49”H x 19”W x 13”D maximum
<b>Cantenna</b>	<p>If a cantenna is located on top of the pole the outer diameter shall be 14” maximum and the cantenna shall be no more than 5 feet tall, including antenna, radio head, mounting bracket, and all other hardware necessary for a complete installation.</p> <p>If the antenna is mounted to the side of the pole it shall be located inside a maximum shroud of 5.5 cubic feet with 16” width (maximum).</p>
<b>RF Equipment Disconnect</b>	Radio frequency equipment shall have a disconnect that meets or exceeds Xcel Energy’s requirements.
<b>Warning Label</b>	Radio frequency warning labels shall be mounted on the equipment and clearly mark both sides of the enclosure and be visible from the ground, roadside, and field side.
<b>Owner Identification</b>	A 4-inch by 6-inch (maximum) plate with the Carrier’s name, location identifying information, and emergency telephone number shall be permanently fixed to the equipment.

### 3.4 Wooden Streetlight with Small Cell Placement Requirements

Small cell shall be located such that all new equipment, including but not limited to Network Provider small cell equipment and Xcel Energy equipment, meets ADA requirements. Xcel Energy, and CCD when applicable, shall approval all fiber and power source locations prior to installation.

[This page intentionally left blank]



Chapter

4

COMBINATION SMALL CELL AND STREETLIGHT



## 4 COMBINATION SMALL CELL AND STREETLIGHT

Refer to Chapter 4 when removing existing streetlight poles and replacing with a combination small cell and streetlight pole.

### 4.1 Purpose

This chapter of the Guide is to be used when replacing an existing streetlight pole with a combination small cell and streetlight pole. Combination small cell and streetlight poles are often referred to as “combination poles”, “Type 3 poles, or “removed and replaced poles” in this Guide. Refer to Chapter 5 for projects involving freestanding small cell installations.

A Type 3 combination small cell and streetlight pole should only be located where an existing streetlight pole can be removed and replaced, or at a new location where it has been identified that a streetlight is necessary. Existing streetlights are typically owned by Xcel Energy; Xcel Energy owned Type 3 combination poles that replace existing streetlights shall meet Xcel Energy standards. Privately-owned Type 3 combination poles shall be approved via CCD’s encroachment permit.

### 4.2 General Guidance

Combination small cell and streetlight permitting applications and aesthetics shall be approved by CCD prior to installation. All equipment shall meet Xcel Energy’s utility requirements and CCD’s design aesthetics. The same small cell pole aesthetic is to be used in the same area to maintain a cohesive appearance. Combination small cell aesthetics and proposed locations shall meet the City and County of Denver’s *Freestanding Small Cell Infrastructure ROW Permit Entrance Requirements*. The lighting design shall follow the luminaire specifications and design requirements set forth in the *City and County of Denver Street Lighting Design Guidelines*.

The City and County of Denver’s *Street Lighting Design Guidelines* provide guidance on luminaire design aesthetics, lighting level criteria, typical streetlight spacing, streetlight specifications, and electrical and streetlight details. The network provider shall provide all documentation required by the *Street Lighting Design Guidelines* to the City during the permitting process.

All small cell carrier equipment shall be housed internal to the pole or hidden behind an exterior shroud. No network provider equipment shall be mounted to the exterior of the pole unless it meets the Type 3B and Type 3C requirements in Section 4.3. Deviations from this guide shall be approved on a case-by-case basis by CCD prior to installation.

### 4.3 Basis of Design

The following pages describe the small cell requirements for installation in the City and County of Denver’s public right of way.

The combination pole design shall match the aesthetics of existing streetlights installed adjacent to the pole. The Carrier shall perform a visual inspection (Online street images are considered sufficient unless the pole standards were updated after the images were published) prior to submitting a permitting application to determine existing aesthetics.

The combination pole components include the foundation, equipment cabinet, upper pole, luminaire, mast arm, luminaire control node if applicable, antenna or antenna enclosure, and all hardware and electrical equipment necessary for a complete assembly.

The small cell components shall also be sized to be visually pleasing. For a combination pole to be considered visually pleasing, the transition between the equipment cabinet and upper pole should be considered. A decorative transition shall be installed over the equipment cabinet upper bolts, or decorative base cover shall be installed to match the equipment cabinet size. The upper pole shall be scaled to 0.5 to 0.75 the size of the equipment cabinet, with a 10-inch minimum outer diameter. All hardware connections shall be hidden from view. No horizontal flat spaces greater than 1.5 inches shall exist on the equipment cabinet to prevent cups, trash, and other objects from being placed on the equipment cabinet. Each pole component shall be architecturally compatible to create a cohesive aesthetic. An example of an unacceptable small cell installation, and acceptable installation can be found in Figures 4-1 and 4-2.

Three variations of combination small cell equipment attachments will be considered for installation in the City and County of Denver. These equipment attachments include a single antenna, a single equipment shroud, or antenna a single exterior equipment shroud when multiple cellular technologies provided by a single carrier are installed on a single pole (ie: LTE and 5G). Each type can be found in Figures 4-3 through 4-5.

Figure 4-1: Unacceptable Type 3 Installation

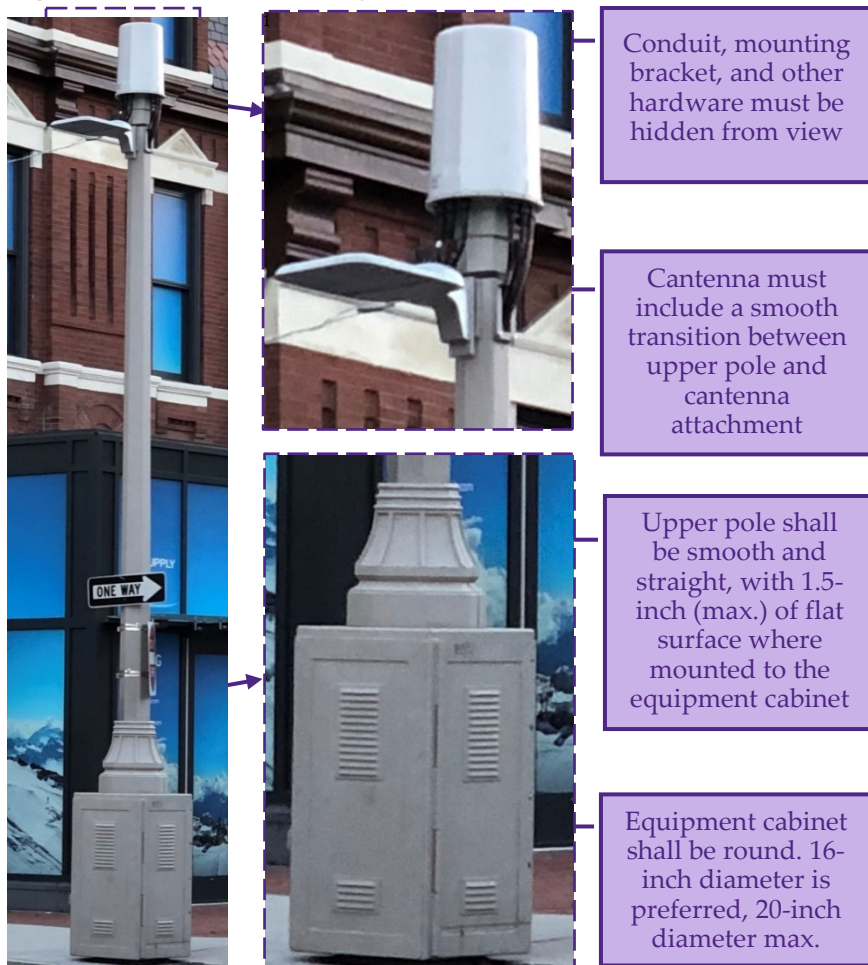

Figure 4-2: Acceptable Type 3 Installation



<sup>1</sup> Images courtesy of Aero Wireless Group

### 4.3.1 Type 3A Combination Pole

The Type 3A combination pole is composed of an equipment cabinet, upper pole, streetlight, and antenna. All equipment shall be located internal, or recessed per Xcel Energy's requirements, to the appropriate enclosure.

Figure 4-3: Type 3A - Combination Pole with Antenna

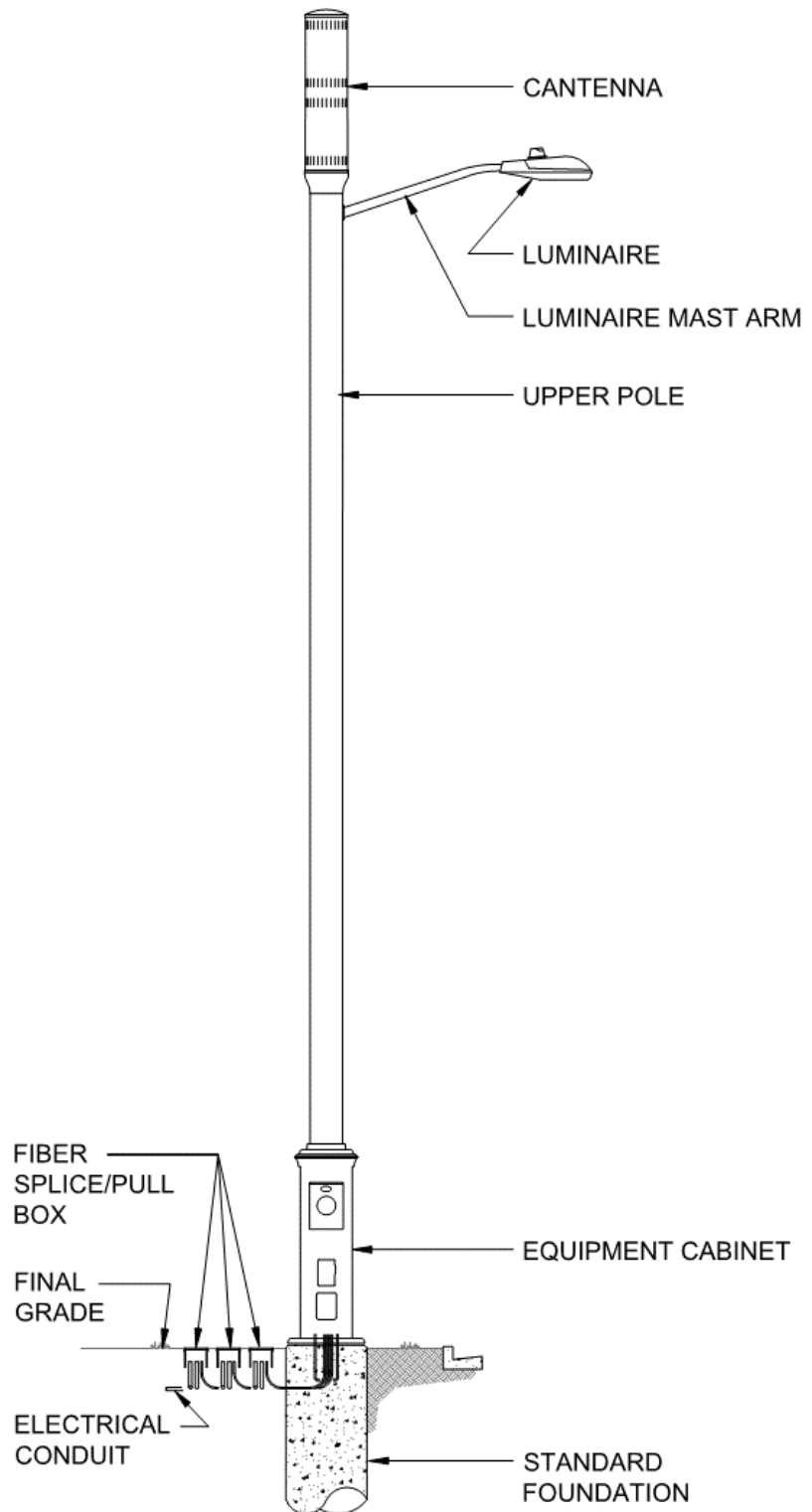

### 4.3.2 Type 3B Combination Pole

The Type 3B combination pole is composed of an equipment cabinet, upper pole, streetlight, and externally mounted equipment shroud. All equipment shall be located internal, shrouded, or recessed per Xcel Energy’s requirements, to the appropriate housing. The antenna, radio head, mounting brackets, and all hardware necessary for a complete installation shall be located inside an aesthetically pleasing equipment shroud, securely strapped to the pole.

Wires and cabling shall be hidden from view. Cables and wires shall internal to the pole until it reaches a cable grommet. Weatherproof grommets shall be installed at all cable entry points. All pole openings shall be weatherproofed to prevent interior rusting of the pole.

Figure 4-4: Type 3B - Combination Pole with Equipment Shroud

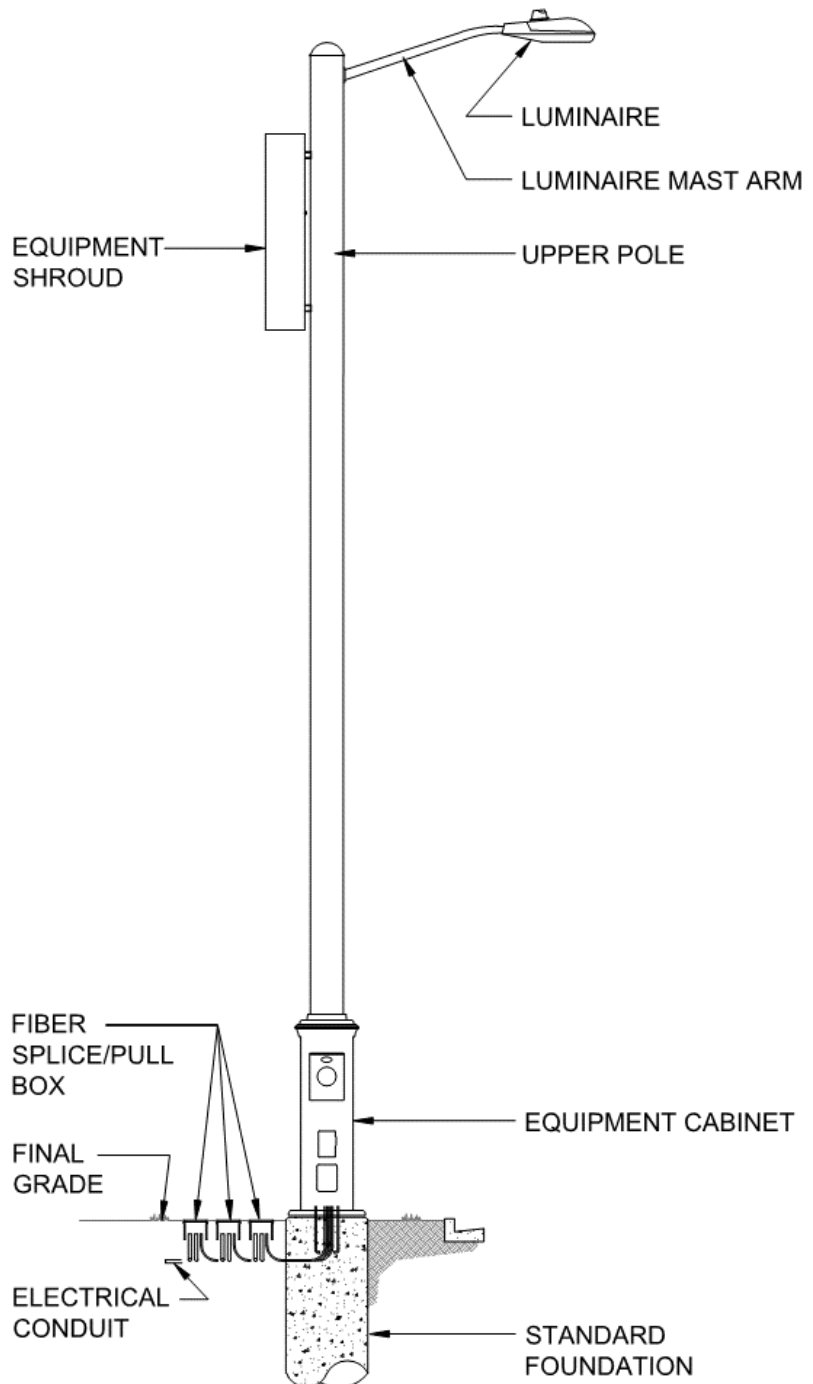

### 4.3.3 Type 3C Combination Pole

The Type 3C combination pole will be allowed when multiple technologies offered by the same carrier are installed on a single pole. To qualify for this permit, the Network Provider must demonstrate that the additional technology cannot be integrated into the equipment cabinet or the antenna. This Type 3C pole is composed of a single equipment cabinet, upper pole, streetlight, antenna, and a single externally mounted equipment shroud.

The additional equipment shroud shall match the combination pole aesthetics. Care should be taken to integrate the mounting attachments into the enclosure design. The enclosure shall be securely strapped to the pole.

A combination small cell and streetlight specification overview is found in Section 4.4. Details showing conduit burial; pull box dimensions; light standard foundations; light standard foundations; grounding; combination small cell and light standards; and pole bases can be found in Appendix A.

**Figure 4-5: Type 3C - Combination Pole with Cantenna and Equipment Shroud**

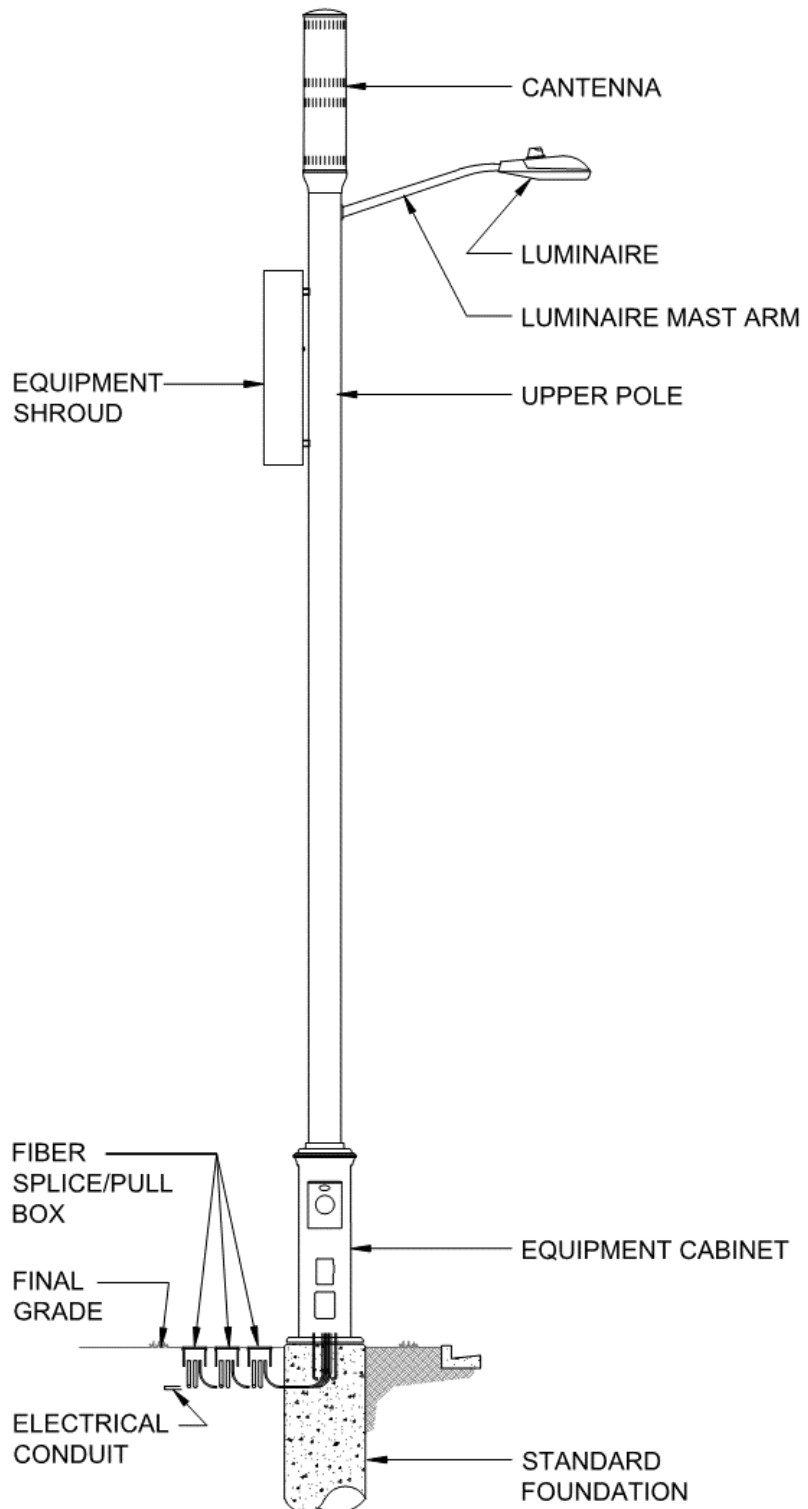

## 4.4 Combination Small Cell and Streetlight Specification Overview

Table 4-1: Streetlight Specification Overview

General Specification Overview			
<b>Luminaire</b>	per <i>Denver Street Lighting Design Guidelines</i> .		
<b>Luminaire Mast Arm</b>	4 feet or 10 feet		
<b>Electrical Service</b>	Per Xcel Energy's requirements Streetlights shall be single phase 120V		
<b>Pole Requirements</b>	At least 15% of the pole design structural capacity shall be reserved for future City IOT installations.		
<b>Pole Type</b>	Round, straight, galvanized steel.		
<b>Pole Color</b>	Equipment cabinet and pole shall be galvanized in accordance with AASHTO M 111.  If the pole is painted to match existing streetlight aesthetics, paint shall be powder coated over zinc paint (Pole and equipment cabinet shall still be galvanized).		
<b>Combination Pole Height</b>	The pole height shall be measured from top of the foundation mast arm mounting bracket. The top of the antenna shall be no higher than 5 feet above the mast arm mounting bracket attachment point.  All luminaires shall be the same height as adjacent streetlights. Luminaires shall be installed as shown in Detail SS-05 and SS-07 in Appendix A.		
	Urban Downtown	Industrial	Residential
	35 feet to 40 feet	35 feet to 40 feet	30 feet
<b>Design Wind Velocity</b>	115 mph minimum per TIA-222 rev G, IBC 2012 with ASC 710, and amendments for local conditions.		
<b>Foundation</b>	Precast concrete or cast-in-place pole foundations shall be designed per the City standard to meet ACI 318. While CCD accepts cast-in-place foundations, precast concrete foundations are preferred and should be installed whenever possible.		
<b>Conduit Sweeps in Foundation</b>	Eight (8) 2" PVC conduit sweeps shall be installed. Conduit shall accommodate CCD electrical, CCD fiber, and Small cell carrier electrical and fiber with up to four (4) spare sweeps for future service.		
<b>Bolt Circle</b>	19.5-inch bolt circle when installing a 16-inch equipment cabinet.  23.5-inch bolt circle when installing a 20-inch equipment cabinet.		
<b>Anchor Bolt Shroud</b>	Anchor bolts shall either be hidden from view, preferred, or treated and painted to match the pole color with CCD approval.		

**Table 4-2: Equipment Cabinet Specification Overview**

Equipment Cabinet Specification Overview			
<b>Equipment Cabinet Style</b>	Round to match diameter below. CCD shall approve other shapes.		
<b>Diameter</b>	16 inches is preferred, 20 inches maximum.		
<b>Height</b>	5'-8" maximum		
<b>Shroud/Cover</b>	All hardware attachments shall be hidden. Equipment cabinet and/or equipment cabinet cover shall not have a flat, horizontal surface larger than 1.5 inches.		
<b>Color</b>	Equipment cabinet and pole shall be galvanized in accordance with AASHTO M 111.  If the pole is painted to match existing streetlight aesthetics, paint shall be powder coated over zinc paint (Pole and equipment cabinet shall still be galvanized).		
<b>Access Doors</b>	<b>Utility access</b>	<b>City access</b>	<b>Carrier access</b>
	Per Xcel Energy's meter access requirements. The meter shall be recessed as much as possible into the pole base	Hand hole	Lockable access door sized to install, maintain, and remove all small cell equipment as needed.
<b>Required Equipment</b>	<b>Utility Equipment*</b>	<b>City Equipment*</b>	<b>Carrier Equipment*</b>
	Per Xcel Energy's requirements	Fused power disconnect	Per small cell carrier requirements
	*All equipment shall be located internal to the equipment cabinet or recessed in the equipment cabinet to meet Utility requirements. All equipment shall be mounted per the Owner's requirements. Pole bases shall be sized to handle the listed equipment and all other equipment required by the Owner.		
<b>Equipment separation</b>	All equipment shall be separated by owner. All access doors shall be secured by owner requirements.		
<b>Ventilation</b>	Passive louvers and/or other passive ventilation systems shall be provided as the primary means of temperature control.		
<b>Motorized Ventilation</b>	If required, fan(s) shall not emit noise greater than 30dBA at one meter (3.28 feet).		

**Table 4-3: Upper Pole Specification Overview**

Upper Pole Specification Overview	
<b>Upper Pole Type</b>	Round, straight, galvanized steel. Pole shall be architecturally compatible with the equipment cabinet.
<b>Potential Shroud</b>	All fixed connections shall be hidden from view.
<b>Upper Pole Diameter</b>	The upper pole shall be scaled to 0.5 to 0.75 times the size of the equipment cabinet with 10" minimum outer diameter. CCD prefers a 10" upper pole diameter.  The pole diameter shall be scaled such that no flat, horizontal surface larger than 1.5 inches exists between the equipment cabinet and upper pole.
<b>Electrical Separation</b>	An internal divider shall separate electrical wiring and fiber, per Owner. Separation of service shall meet Xcel Energy's requirements.
<b>Grommets</b>	Weatherproof grommets shall be integrated into the pole design to allow cable to exit the pole, for external shrouds, without water seeping into the pole.
<b>Hand Holes</b>	A hand hole shall be provided at the top of the extension pole to maintain CCD fiber and electrical service for streetlights and future IOT attachments. An optional hand hole may be provided at the bottom of the upper pole.

**Table 4-4: Cantenna Specification Overview**

Antenna Enclosure Specification Overview	
<b>Cantenna Diameter</b>	14-inch maximum outer diameter with shroud.
<b>Cantenna Height</b>	The cantenna height - including antenna, radio equipment, conduit or wires, brackets, transition shroud, and all other hardware required for a complete installation - from the top of the mast arm connection to the top of the cantenna shall not exceed 5 feet.
<b>Antenna Enclosure</b>	If an antenna is located on the side of the pole, the antenna, radio equipment, brackets, and all other hardware required for a complete installation shall fit behind a 38"H x 16"W x 12"D maximum shroud, securely strapped to the pole.
<b>Shroud</b>	The antenna and antenna pole attachment shall be shrouded to meet CCD aesthetics. A tapered transition between the upper pole and cantenna shall be included.
<b>Color</b>	Antenna shroud shall be colored to match pole.
<b>Warning Label</b>	If required, radio frequency warning labels shall be mounted exterior to the pole.
<b>Owner Identification</b>	A 4-inch by 6-inch (maximum) plate with the Carrier's name, location identifying information, and emergency telephone number shall be permanently fixed to the pole.



## 4.5 Placement Requirements

A Type 3 combination small cell and streetlight pole should only be located where an existing pole (usually Xcel Energy) can be removed and replaced, or at a new location where it has been identified that a streetlight is necessary. Type 3 poles can either be owned by Xcel Energy (preferred – as approved by Xcel Energy) or by the applicant (as approved via Encroachment Permit by the City and County of Denver).

When submitting to Xcel Energy, the pole design and configuration shall be per Xcel Energy standards. When submitting to CCD as a privately-owned Type 3 pole, the pole shall be located as follows:

- In a manner that does not impede, obstruct, or hinder pedestrian or vehicular travel.
- In alignment with existing trees, utility poles, and streetlights.
- Within the street amenity zone whenever possible.
- Equal distance between trees when possible, with a minimum of 15 feet separation such that no proposed disturbance shall occur within the critical root zone of any tree.
- With appropriate clearance from existing utilities.
- Outside of the 20-foot equipment clear zone (for base cabinets less than 18-inches in diameter) or 30-foot clear sight triangle (for base cabinets equal to or greater than 18-inches in diameter) at intersection corners.
- 10 feet away from the triangle extension of an alley way flare.
- Any new Type 3 pole general location and spacing shall be as determined by the *City and County of Denver Street Lighting Guidelines*.

[This page intentionally left blank]

Chapter

5

**FREESTANDING SMALL CELL INFRASTRUCTURE**



## 5 FREESTANDING SMALL CELL INFRASTRUCTURE

Refer to Chapter 5 when installing freestanding small cell poles.

### 5.1 Purpose

This chapter of the Guide is to be used when installing a freestanding small cell. Refer to Chapter 4 for projects involving combination small cell installations.

### 5.2 General Guidance

The specifications provided in this chapter are for single carrier with single technology installations within the public ROW only. Dual carrier, dual technology installations, or small cell locations not in the public ROW may vary from these guidelines with CCD approval.

All freestanding small cell permitting applications shall be approved by CCD prior to installation. All equipment shall meet Xcel Energy's utility requirements and the City and County of Denver's design aesthetics.

The same small cell pole aesthetic is to be used along adjacent blocks to maintain a cohesive appearance. Freestanding small cell aesthetics and proposed locations shall meet the City and County of Denver's *Freestanding Small Cell Infrastructure ROW Permit Entrance Requirements*.

All small cell carrier equipment shall be housed internal to the equipment cabinet or hidden behind the cantenna. No network provider equipment shall be strapped to the outside of the pole. If a dual-carrier pole is approved by the CCD, all the network provider equipment shall be located internal to the pole and cantenna.

Deviations from this guide shall be approved on a case-by-case basis by CCD prior to installation

### 5.3 Basis of Design

The following pages describe the small cell requirements for installation in the City and County of Denver's public right of way.

Figure 5-1: Freestanding Small Cell Pole



Photo courtesy of Aero Wireless Group

The pole design shall match the aesthetics of existing streetlights installed adjacent to the pole. The Carrier shall perform a visual inspection (Online street images are considered sufficient unless the pole standards were updated after the images were published) prior to submitting a permitting application to determine existing aesthetics.

The small cell components shall be sized to be visually pleasing. For a pole to be considered visually pleasing, the transition between the equipment cabinet and upper pole should be considered. A decorative transition shall be installed over the equipment cabinet upper bolts, or decorative base cover shall be installed to match the equipment cabinet size. The upper pole shall be scaled to 0.5 to 0.75 the size of the equipment cabinet, with a 10-inch minimum outer diameter. All hardware connections shall be hidden from view. No horizontal flat spaces greater than 1.5 inches shall exist on the equipment cabinet to prevent cups, trash, and other objects from being placed on the equipment cabinet. Each pole component shall be architecturally compatible to create a cohesive aesthetic. An example of an unacceptable small cell installation, and acceptable installation can be found in Figures 5-2 and 5-3.

Figure 5-2: Unacceptable Type 4 Installation

Figure 5-3: Acceptable Type 4 Installation



<sup>2</sup> Images courtesy of Aero Wireless Group

Freestanding small cell pole components include the foundation, equipment cabinet, upper pole, antenna, and all hardware and electrical equipment necessary for a complete assembly, as shown in Figure 5-4. A freestanding small cell specification overview is found in Appendix B.

Figure 5-4: Freestanding Small Cell Assembly

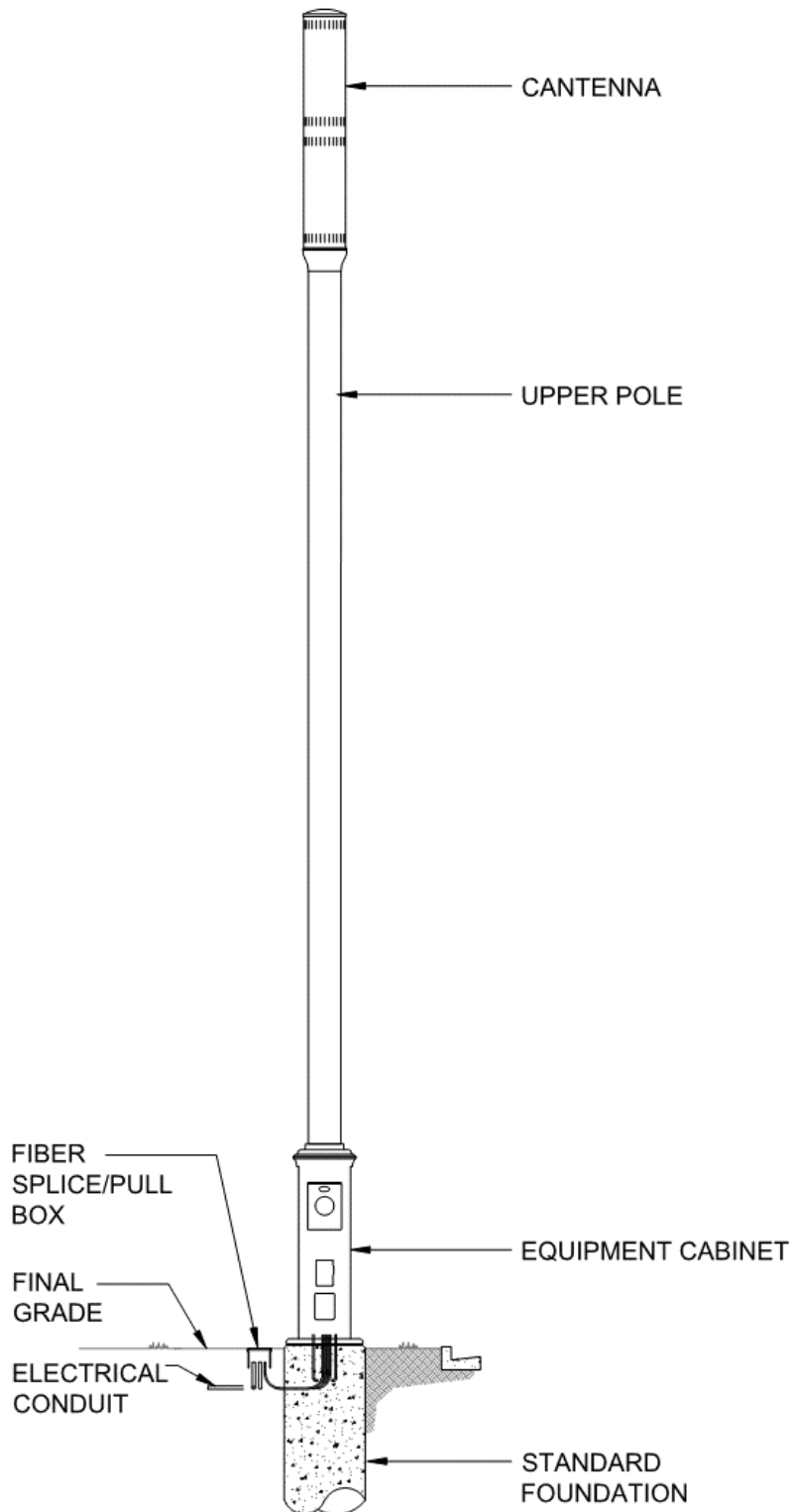

## 5.4 Freestanding Small Cell Specification Overview

Table 5-1: Freestanding Small Cell Infrastructure Specification Overview

General Specification Overview					
<b>Electrical Service</b>	Per Xcel Energy's requirements				
<b>Pole Type</b>	Round, straight, galvanized steel				
<b>Pole Color</b>	Equipment cabinet and pole shall be galvanized in accordance with AASHTO M 111.  If the pole is painted to match existing streetlight aesthetics, paint shall be powder coated over zinc paint (Pole and equipment cabinet shall still be galvanized).				
<b>Pole Height</b>	The freestanding small cell shall not exceed 30 feet. Pole shall be measured from the top of the foundation to the top of the antenna.				
<b>Design Wind Velocity</b>	115 mph minimum per TIA-222 rev G, IBC 2012 with ASC 710, and amendments for local conditions.				
<b>Foundation</b>	Precast concrete or cast-in-place pole foundations shall be designed per CCD standard to meet ACI 318. While CCD accepts cast-in-place foundations, precast concrete foundations are preferred and should be installed whenever possible.				
<b>Conduit Sweeps in Foundation</b>	Eight (8) 2" PVC conduit sweeps shall be required. Conduit shall accommodate small cell carrier electrical and fiber with up to four (4) spare sweeps for future service.				
<b>Bolt Circle</b>	19.5-inch bolt circle when installing a 16-inch equipment cabinet.  23.5-inch bolt circle when installing a 20-inch equipment cabinet.				
<b>Anchor Bolt Shroud</b>	Anchor bolts shall either be hidden from view, preferred, or treated and painted to match the pole color with CCD approval.				
<b>Equipment Cabinet Style</b>	Round to match diameter below. CCD shall approve other shapes.				
<b>Equipment Cabinet Diameter</b>	16 inches is preferred, 20 inches maximum.				
<b>Equipment Cabinet Height</b>	5'-8" maximum				
<b>Equipment Cabinet Shroud/Cover</b>	All hardware attachments shall be hidden. Equipment cabinet and equipment cabinet cover shall not have a flat, horizontal surface larger than 1.5 inches.				
<b>Equipment Cabinet Access Doors</b>	Lockable access door sized to install, maintain, and remove all small cell equipment as needed shall meet Carrier's requirements.  Utility access shall be per Xcel Energy's requirements. The meter shall be recessed into the pole base				
<b>Equipment Cabinet Required Equipment</b>	All equipment shall be located internal to the equipment cabinet or recessed as much as possible in the equipment cabinet to meet Utility requirements. All equipment shall be mounted per the Owner's requirements. Pole bases shall be sized to handle the listed equipment and all other equipment required by the Owner.				
	<table border="1"> <thead> <tr> <th>Utility Equipment</th> <th>Carrier Equipment</th> </tr> </thead> <tbody> <tr> <td>Per Xcel Energy requirements</td> <td>Per small cell carrier requirements</td> </tr> </tbody> </table>	Utility Equipment	Carrier Equipment	Per Xcel Energy requirements	Per small cell carrier requirements
Utility Equipment	Carrier Equipment				
Per Xcel Energy requirements	Per small cell carrier requirements				
<b>Ventilation</b>	Passive louvers and/or other passive ventilation systems shall be provided as the primary means of temperature control.				

### General Specification Overview

<b>Motorized Ventilation</b>	If required, fan(s) shall not emit noise greater than 30dBA at one meter (3.28 feet).
<b>Upper Pole Diameter</b>	The upper pole shall be scaled to 0.5 to 0.75 times the size of the equipment cabinet with 10" minimum outer diameter. CCD prefers a 10" upper pole diameter.  The pole diameter shall be scaled such that no flat, horizontal surface larger than 1.5 inches exists between the equipment cabinet and upper pole.
<b>Cantenna</b>	Antenna and pole attachment shall be shrouded to meet CCD aesthetics. A tapered transition between the upper pole and cantenna shall be included.
<b>Cantenna Diameter</b>	14-inch maximum outer diameter with shroud.
<b>Cantenna Height</b>	The cantenna height - including antenna, radio equipment, brackets, transition shroud, and all other hardware required for a complete installation - to the pole shall not exceed 5'-8".
<b>Cantenna Color</b>	Antenna shroud shall be colored to match pole.
<b>Warning Label</b>	If required, radio frequency warning labels shall be mounted exterior to the pole.
<b>Owner Identification</b>	A 4-inch by 6-inch (maximum) plate with the Carrier's name, location identifying information, and emergency telephone number shall be permanently fixed to the pole.

## 5.5 Placement Requirements

All Type 4 freestanding small cell poles shall be privately owned and must be permitted by CCD via the *Freestanding Small Cell Infrastructure ROW Permit Entrance Requirements*.

- In a manner that does not impede, obstruct, or hinder pedestrian or vehicular travel.
- So as not to be located along the frontage of a Historic building, deemed historic on a federal, state, or local level.
- So as not to significantly create a new obstruction to property sight lines.
- At the intersection of property lines, or along secondary property street facing.
- Within the street amenity zone whenever possible.
- In alignment with existing trees, utility poles, and streetlights.
- Equal distance between trees when possible, with a minimum of 15 feet separation such that no proposed disturbance shall occur within the critical root zone of any tree.
- With appropriate clearance from existing utilities.
- Outside of the 20-foot equipment clear zone (for base cabinets less than 18-inches in diameter) or 30-foot clear sight triangle (for base cabinets equal to or greater than 18-inches in diameter) at intersection corners as shown in Figure 5-7.
- 10 feet away from the triangle extension of an alley way flare.
- Shall not be located within 100 feet of the apron of a fire station or other adjacent emergency service facility.
- No closer than 250 feet away, radially, from another privately-owned Type 4 freestanding small cell.

Figure 5-5: Freestanding Small Cell spacing radius

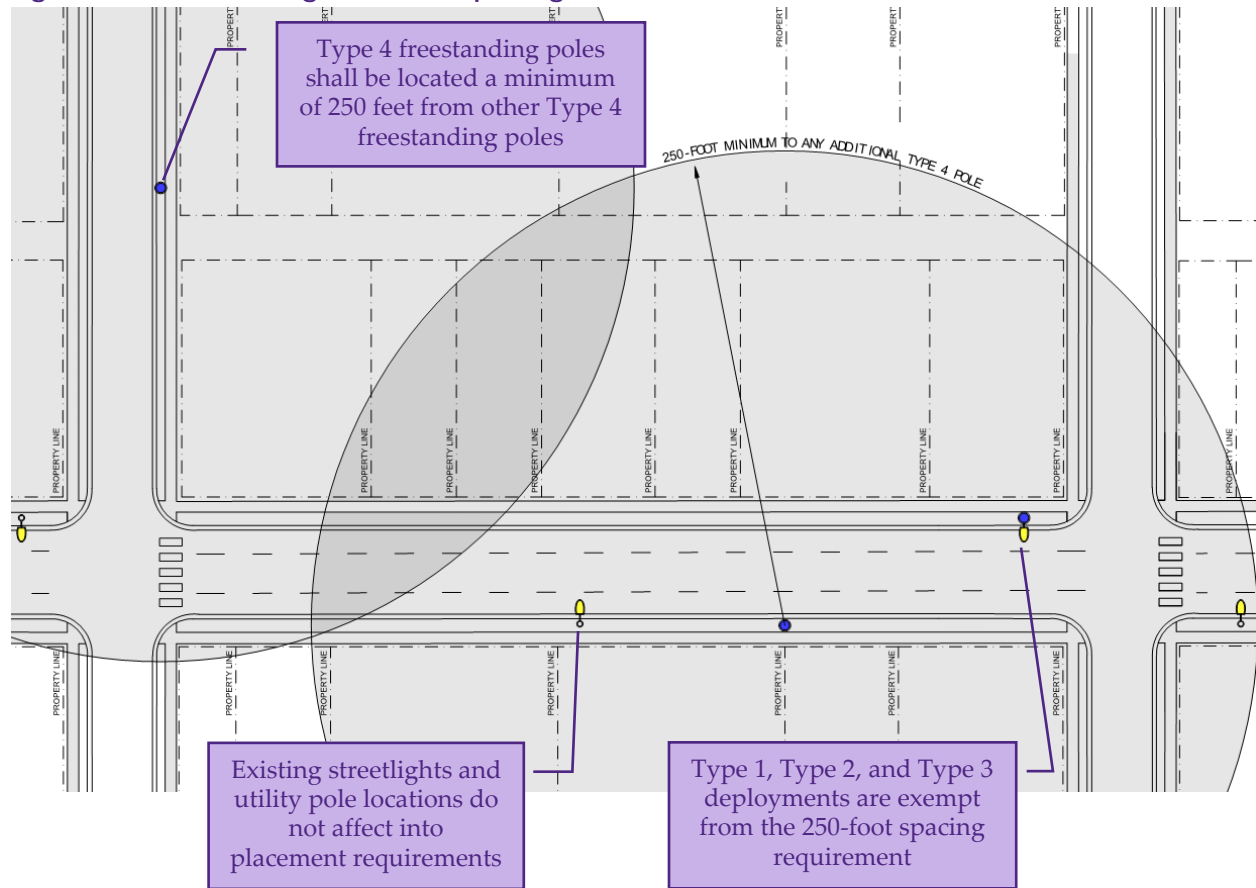

Figure 5-5 shows freestanding small cells which shall be a minimum of 250 feet apart radially. This radius extends around corners and into alleys. They shall be located in line with trees, existing streetlights, utility poles, and other furniture located in the amenity zone, as shown in Figure 5-6.



Figure 5-6: Freestanding small cell in amenity zone



Freestanding small cells shall be located such that they in no way impede, obstruct, or hinder the usual pedestrian or vehicular travel, affect public safety, obstruct the legal access to or use of the public ROW, violate applicable law, violate or conflict with public ROW design standards, specifications, or design district requirements, violate the Federal Americans with Disabilities Act of 1990, or in any way create a risk to public health, safety, or welfare.

Free standing small cells shall be located within the ROW and off set from the sidewalk as shown in Figure 5-7.

Figure 5-7: Standalone Small Cell sight-line requirements

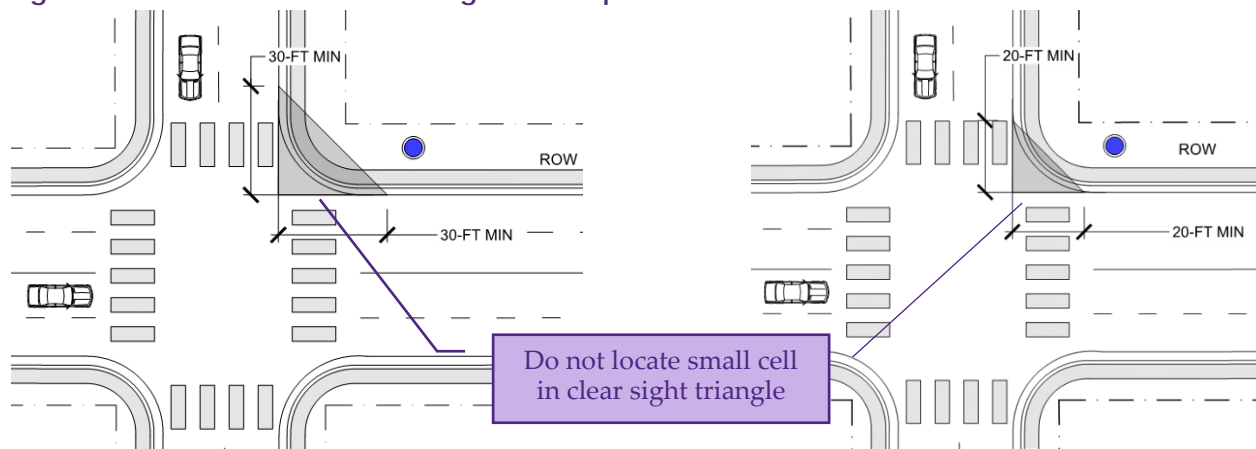

Freestanding small cells shall be located at intersecting property lines as much as possible. Whenever possible, the freestanding small cell shall be located on the secondary street. Small cells shall also be located

a minimum of 15 feet away from trees to prevent disturbance within the critical root zone of any tree, as shown in Figure 5-8.

The small cells shall not be installed between the perpendicular extension of the primary street-facing wall plane of any single or two-family residence as shown in

Figure 5-9.

**Figure 5-8: Freestanding small cell location between property and trees**



**Figure 5-9: Freestanding Small Cell between property lines**

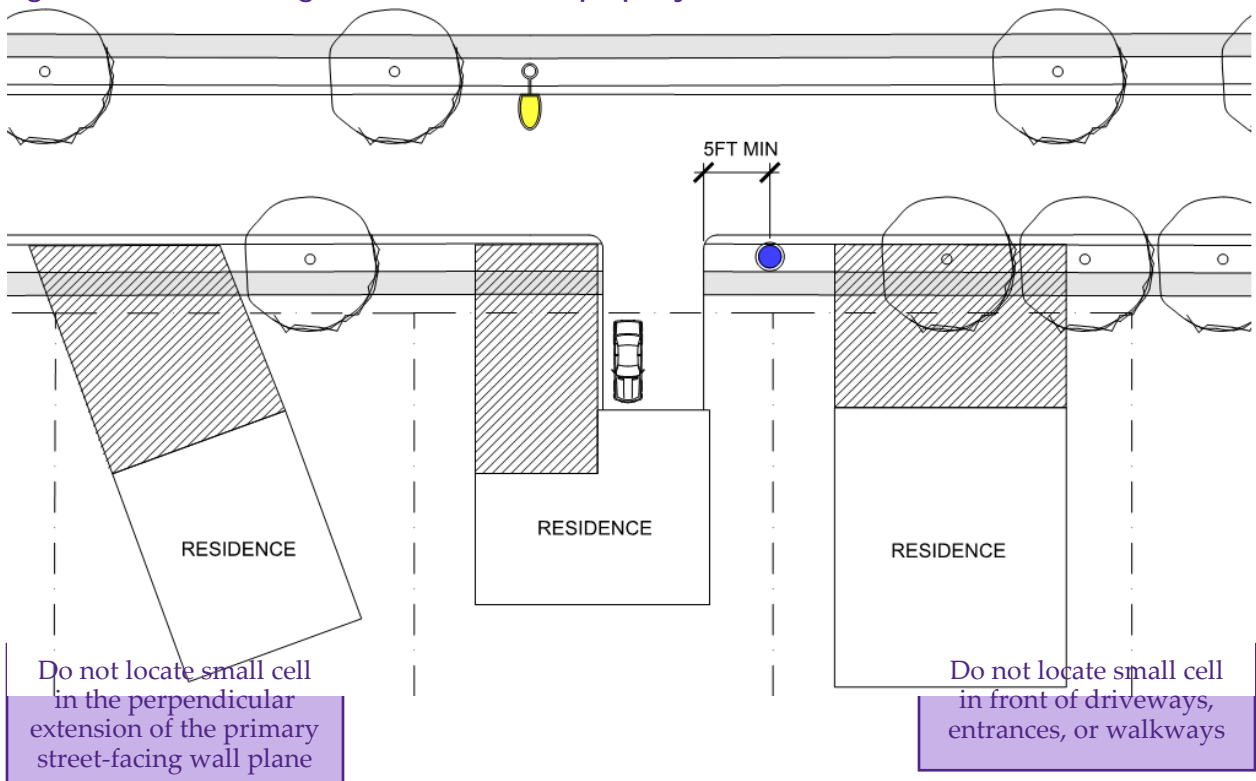

Figure 5-10: Small Cell in Commercial Area



When located adjacent to a commercial establishment, such as a shop or restaurant, care should be taken to locate the small cell such that it does not negatively impact the business. Small cells shall not be located in-front of store front windows, primary walkways, primary entrances or exits, or in such a way that it would impede a delivery to the building. Small cells should be located between properties as much as possible as shown in Figure 5-10.

[This page intentionally left blank]

# A



## A DETAILS

The following pages provide details to be used in all City and County of Denver small cell installations. These pages detail the components required for each type of small cell installation, conduit burial, pull box dimensions, pole bases, grounding, and foundations.

The details include the City and County of Denver electrical requirements and Xcel Energy electrical requirements. The appropriate details, based on either the City and County of Denver specification or Xcel Energy specification, should be selected based on who will own and maintain the system after installation.

Refer to Appendix A for construction details relating to small cells.

## List of Details

Typical Utility Pole Mounted Detail .....	SS-01
Typical Utility Pole Strand Mounted Detail .....	SS-02
Typical Combination Small Cell – Streetlight on Wooden Pole.....	SS-03
Typical Combination Pole Equipment Cabinet Detail .....	SS-04
Typical Type 3A Combination Pole Detail.....	SS-05
Typical Type 3B Combination Pole Detail .....	SS-06
Typical Type 3C Combination Pole Detail.....	SS-07
Typical Freestanding Small Cell Pole Detail.....	SS-08
Typical Type 3 Combination Pole Conduit Burial Detail.....	SS-09
Typical Type 1, Type 2, and Type 4 Conduit Burial Detail.....	SS-10
Pull Box/ Splice Box Typical Dimensions .....	SS-11
Typical In-Grade Pull Box/ Splice Box Detail .....	SS-12
Typical Small Cell Electrical Detail in Softscape .....	SS-13
Typical Small Cell Electrical Detail in Hardscape .....	SS-14
Typical Small Cell Electrical Detail Notes .....	SS-15
Typical Non-Breakaway Pole Base Standard Detail .....	SS-16
Typical Foundation Structural Detail .....	SS-17
Typical Foundation Structural Detail .....	SS-18
Typical Foundation Structural Detail .....	SS-19
Typical Foundation Structural Detail .....	SS-20

# CCD SMALL CELL SPECIFICATIONS

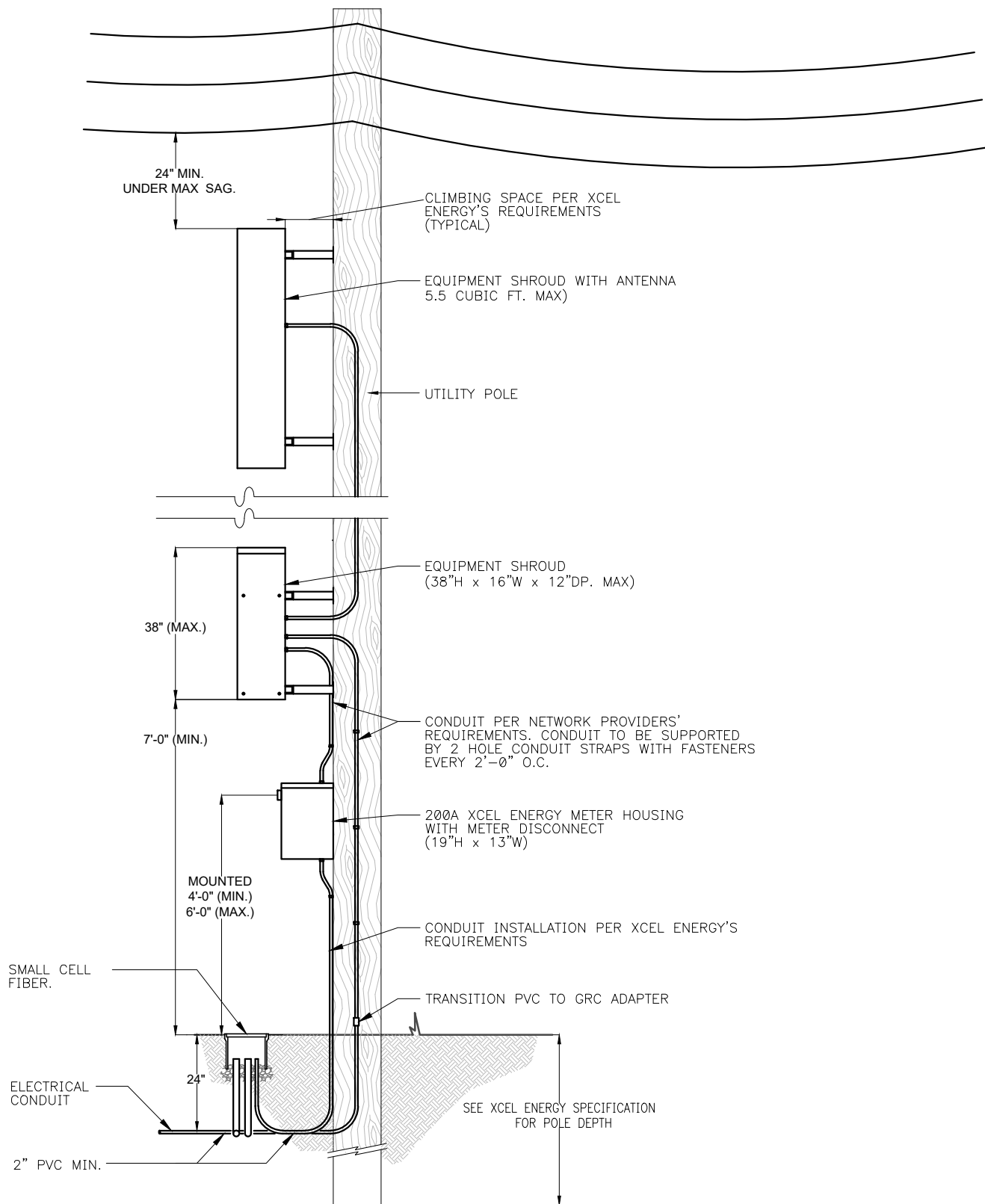

**TYPE 1A UTILITY POLE WITH MOUNTED EQUIPMENT SHROUD**



City and County of Denver  
Department of Public Works

Date:  
April 2018

TYPICAL UTILITY POLE MOUNTED DETAIL

Std. Dwg. No.  
SS-01

CCD SMALL CELL SPECIFICATIONS

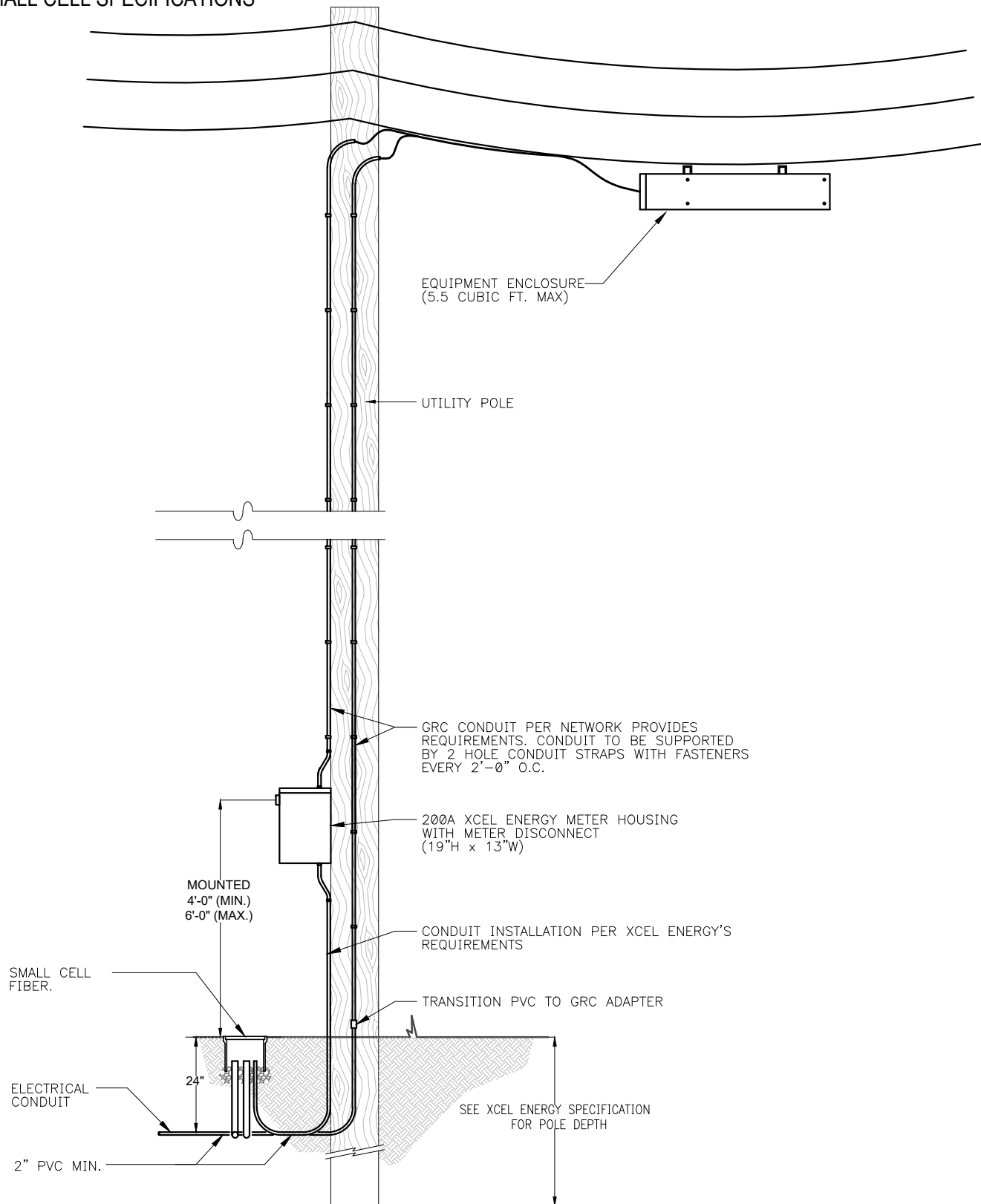

TYPE 1B UTILITY POLE WITH STRAND MOUNTED SHROUD



City and County of Denver  
Department of Public Works

Date:  
April 2018

TYPICAL UTILITY POLE STRAND MOUNTED DETAIL

Std. Dwg. No.  
SS-02



# CCD SMALL CELL SPECIFICATIONS

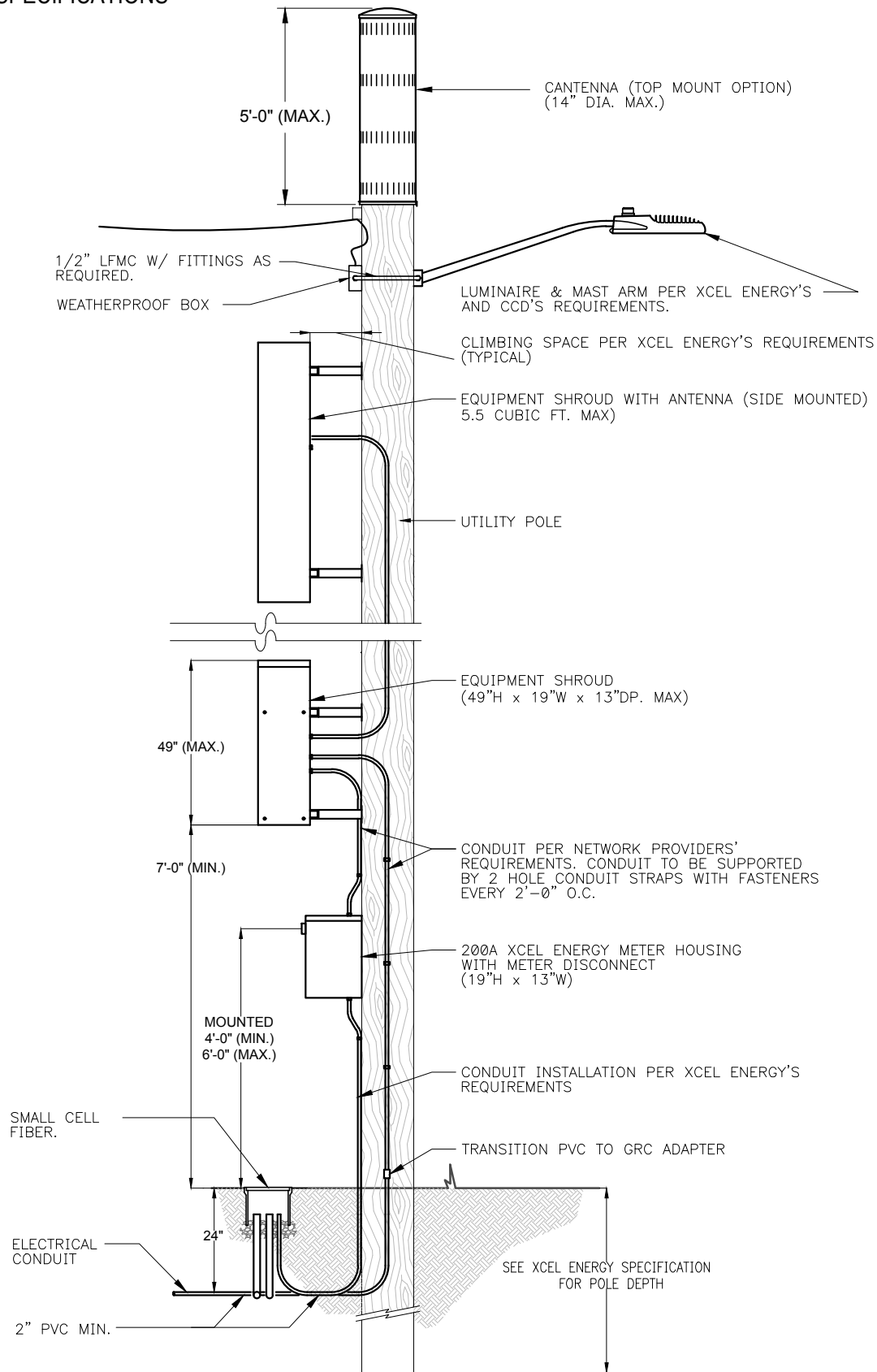

City and County of Denver  
Department of Public Works

Date:  
April 2018

TYPICAL COMBINATION SMALL CELL-STREETLIGHT ON  
WOODEN POLE

Std. Dwg. No.  
SS-03

CCD SMALL CELL SPECIFICATIONS

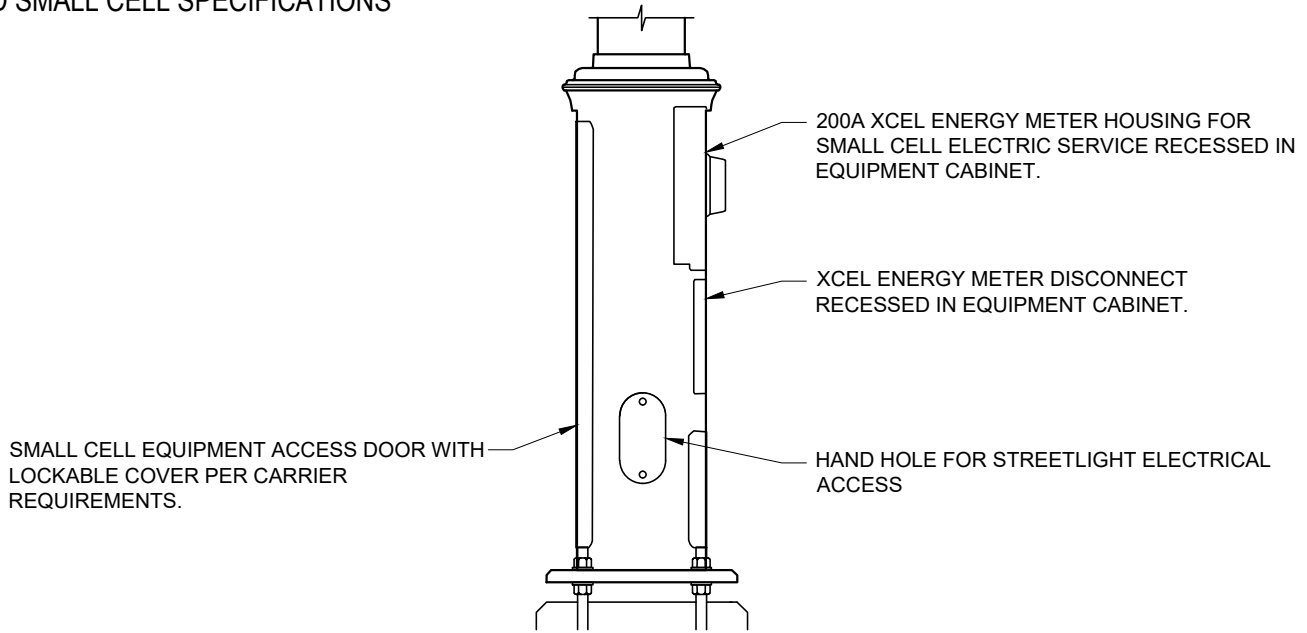

SIDE VIEW

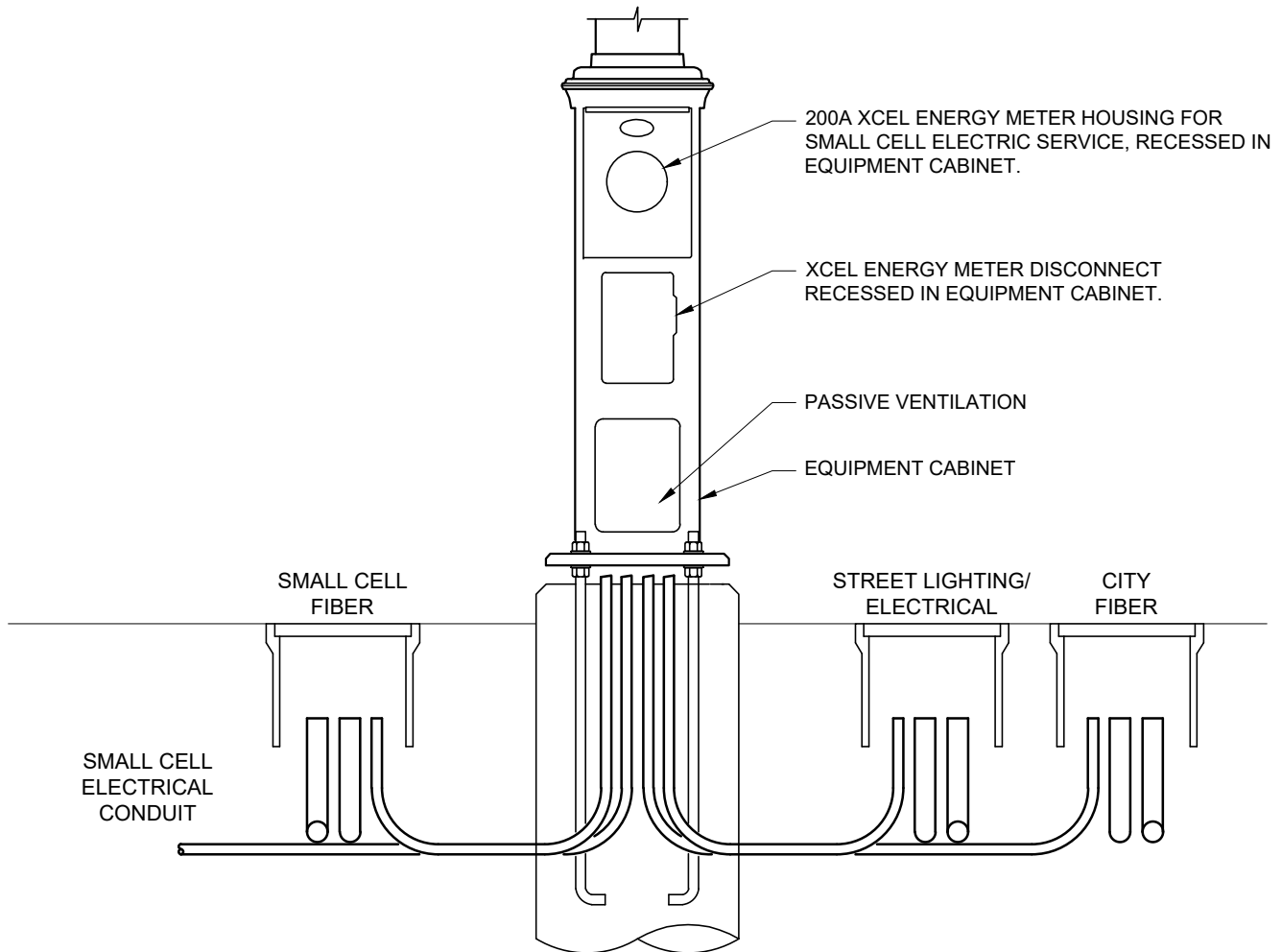

City and County of Denver  
Department of Public Works

Date:  
April 2018

TYPICAL COMBINATION POLE EQUIPMENT  
CABINET DETAIL

Std. Dwg. No.  
SS-04

# CCD SMALL CELL SPECIFICATIONS

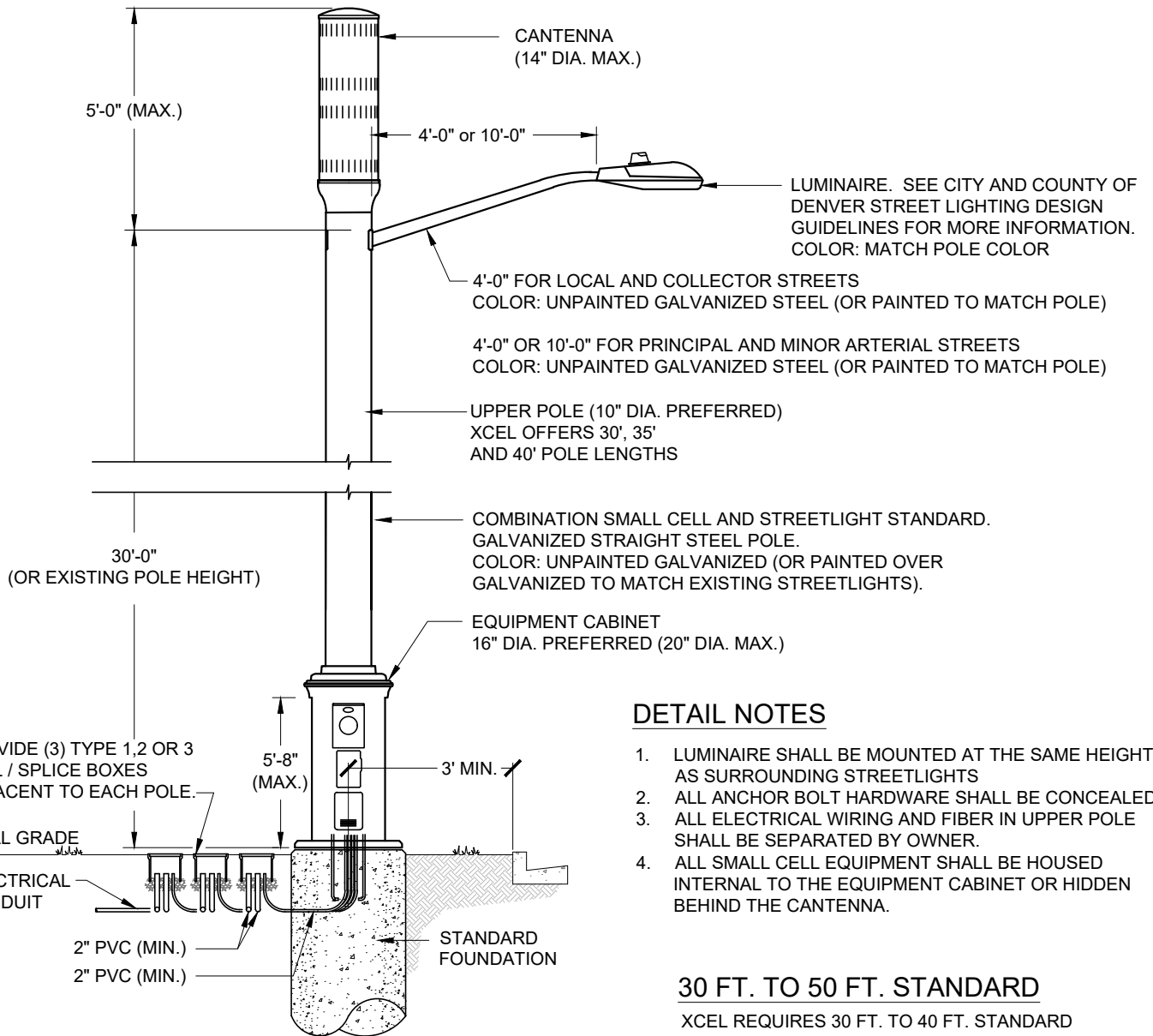
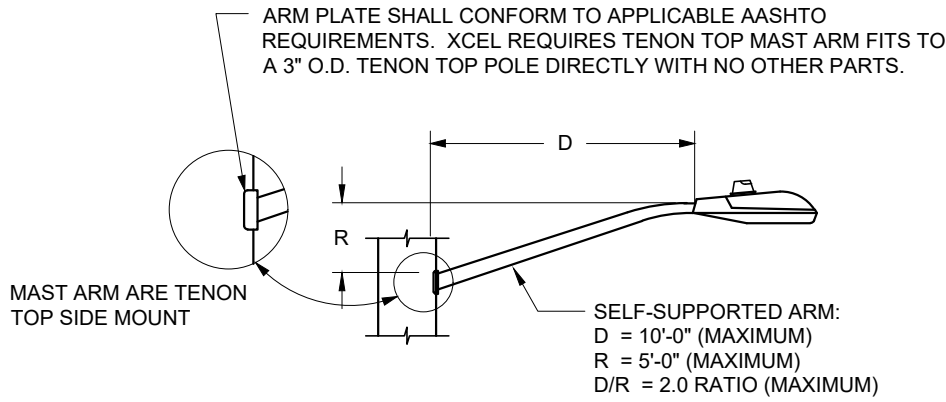

## DETAIL NOTES

1. LUMINAIRE SHALL BE MOUNTED AT THE SAME HEIGHT AS SURROUNDING STREETLIGHTS
2. ALL ANCHOR BOLT HARDWARE SHALL BE CONCEALED.
3. ALL ELECTRICAL WIRING AND FIBER IN UPPER POLE SHALL BE SEPARATED BY OWNER.
4. ALL SMALL CELL EQUIPMENT SHALL BE HOUSED INTERNAL TO THE EQUIPMENT CABINET OR HIDDEN BEHIND THE CANTENNA.

## 30 FT. TO 50 FT. STANDARD

XCEL REQUIRES 30 FT. TO 40 FT. STANDARD



City and County of Denver  
 Department of Public Works

Date:  
 April 2018

TYPICAL TYPE 3A COMBINATION POLE DETAIL

Std. Dwg. No.  
 SS-05

# CCD SMALL CELL SPECIFICATIONS

ARM PLATE SHALL CONFORM TO APPLICABLE AASHTO REQUIREMENTS. XCEL REQUIRES TENON TOP MAST ARM FITS TO A 3" O.D. TENON TOP POLE DIRECTLY WITH NO OTHER PARTS.

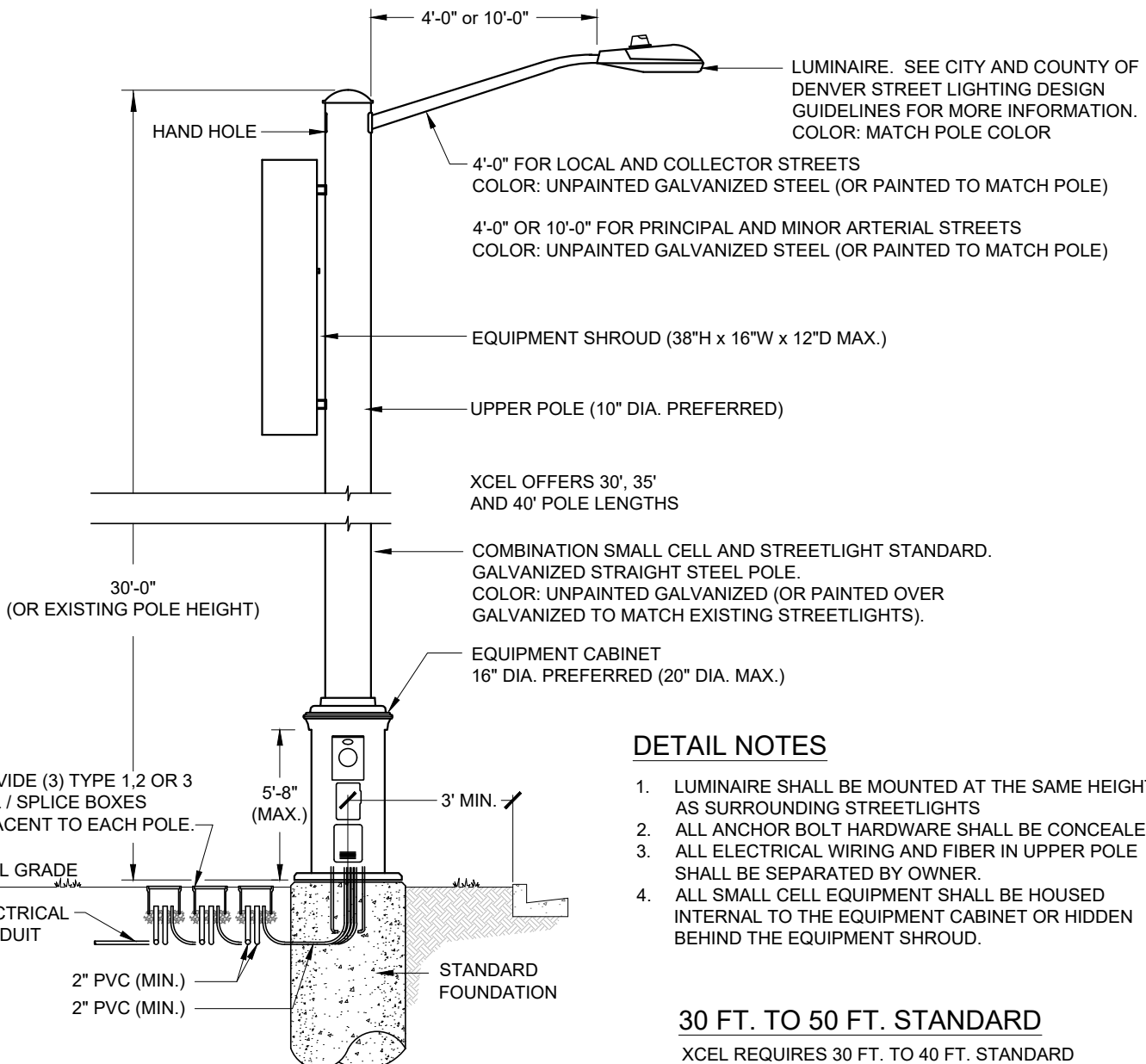
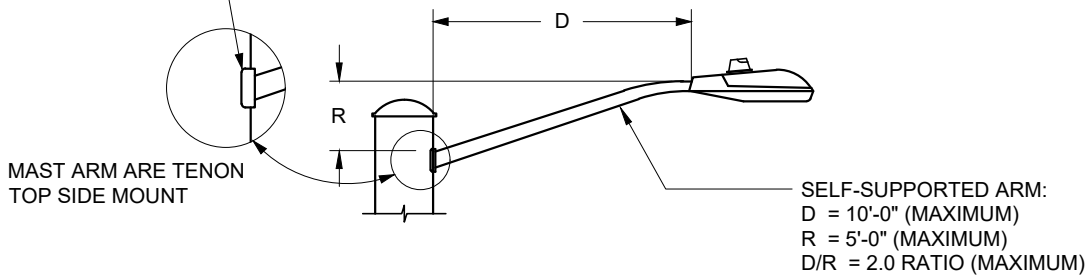

### DETAIL NOTES

1. LUMINAIRE SHALL BE MOUNTED AT THE SAME HEIGHT AS SURROUNDING STREETLIGHTS
2. ALL ANCHOR BOLT HARDWARE SHALL BE CONCEALED.
3. ALL ELECTRICAL WIRING AND FIBER IN UPPER POLE SHALL BE SEPARATED BY OWNER.
4. ALL SMALL CELL EQUIPMENT SHALL BE HOUSED INTERNAL TO THE EQUIPMENT CABINET OR HIDDEN BEHIND THE EQUIPMENT SHROUD.

### 30 FT. TO 50 FT. STANDARD

XCEL REQUIRES 30 FT. TO 40 FT. STANDARD

	City and County of Denver Department of Public Works	Date: April 2018
	TYPICAL TYPE 3B COMBINATION POLE DETAIL	Std. Dwg. No. SS-06

# CCD SMALL CELL SPECIFICATIONS

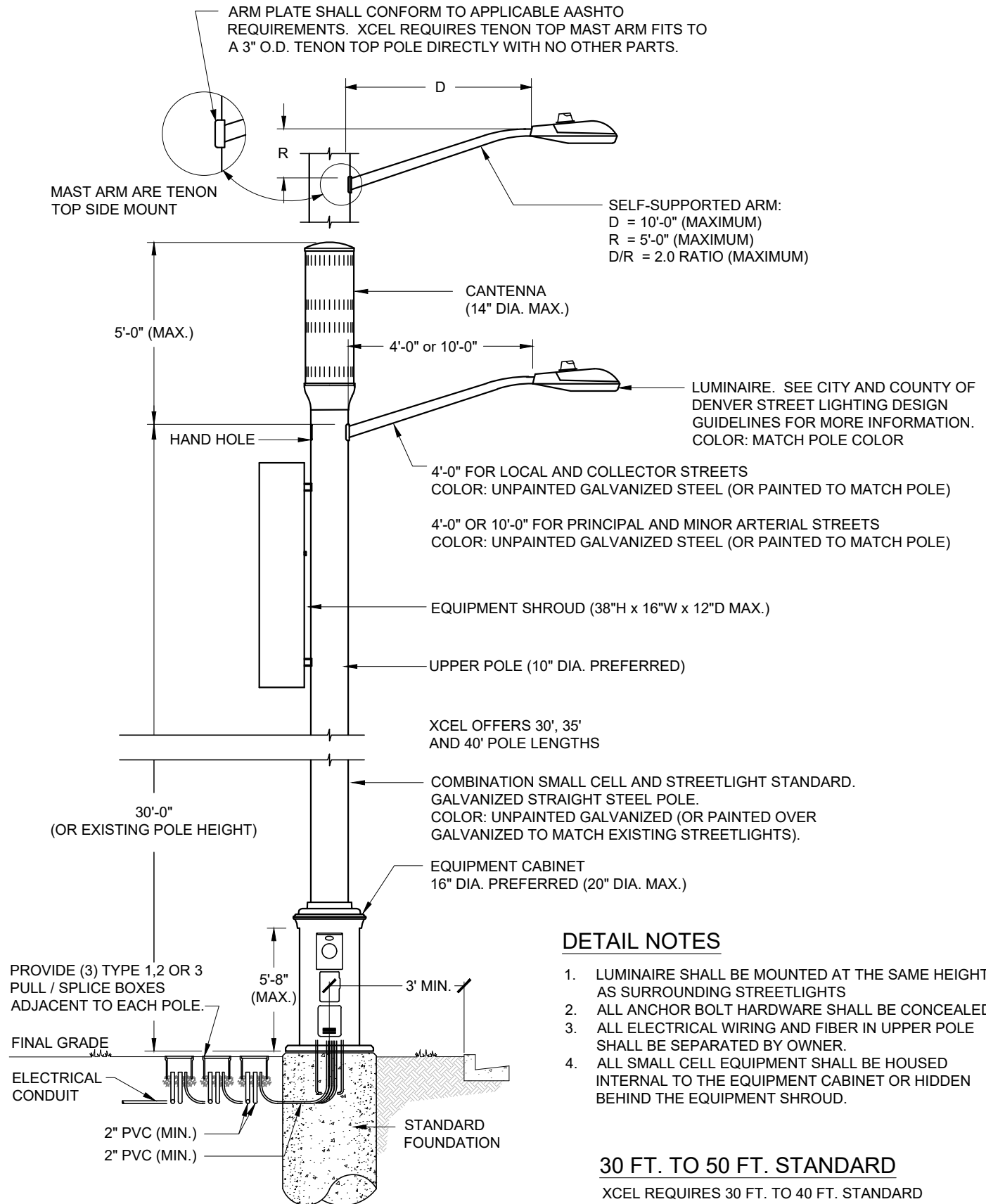

City and County of Denver  
 Department of Public Works

Date:  
 April 2018

TYPICAL TYPE 3C COMBINATION POLE DETAIL

Std. Dwg. No.  
 SS-07

CCD SMALL CELL SPECIFICATIONS

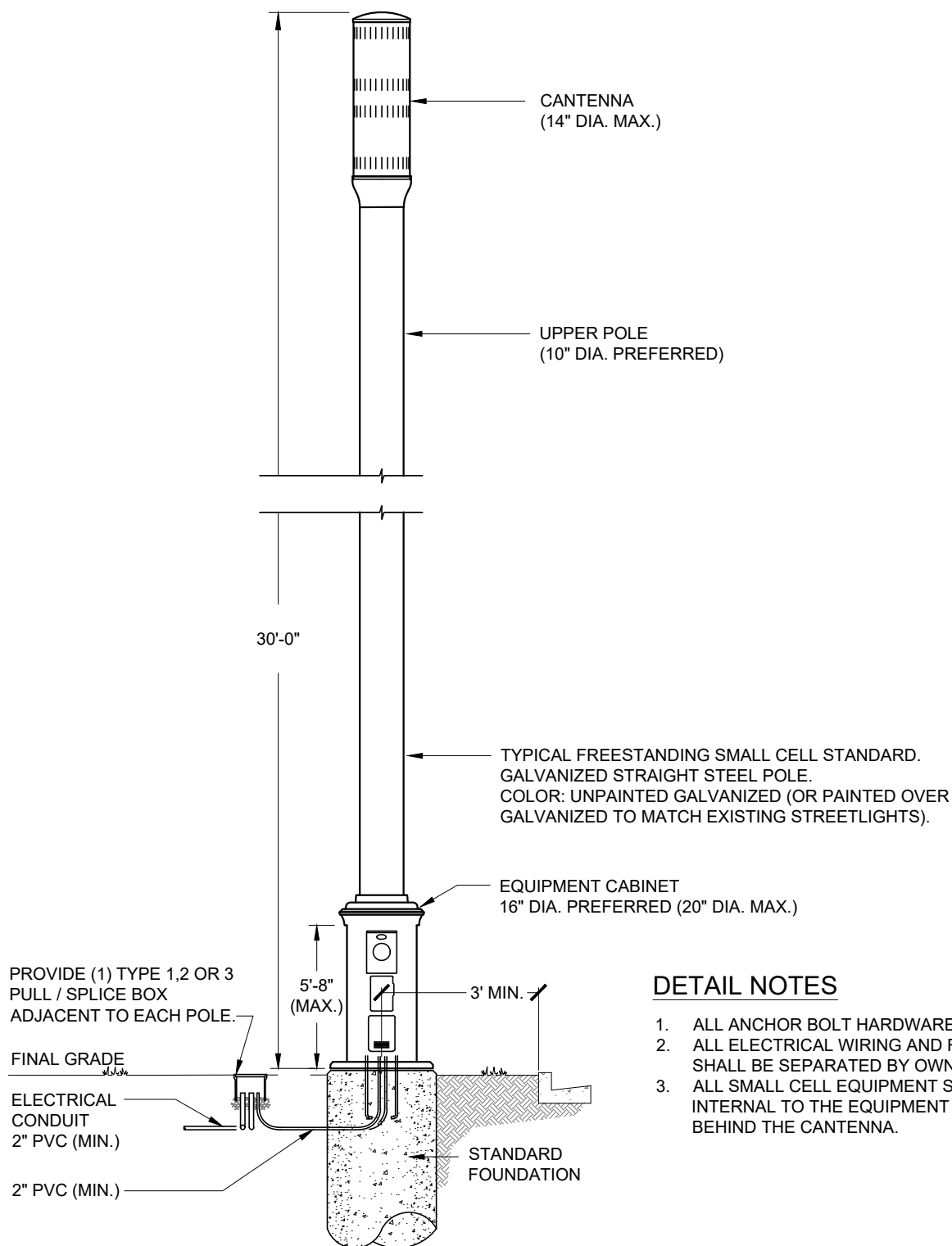

**DETAIL NOTES**

1. ALL ANCHOR BOLT HARDWARE SHALL BE CONCEALED.
2. ALL ELECTRICAL WIRING AND FIBER IN UPPER POLE SHALL BE SEPARATED BY OWNER.
3. ALL SMALL CELL EQUIPMENT SHALL BE HOUSED INTERNAL TO THE EQUIPMENT CABINET OR HIDDEN BEHIND THE CANTENNA.

**30 FT. STANDARD**

	City and County of Denver Department of Public Works	Date: April 2018
	TYPICAL FREESTANDING SMALL CELL POLE DETAIL	Std. Dwg. No. SS-08

# CCD SMALL CELL SPECIFICATIONS

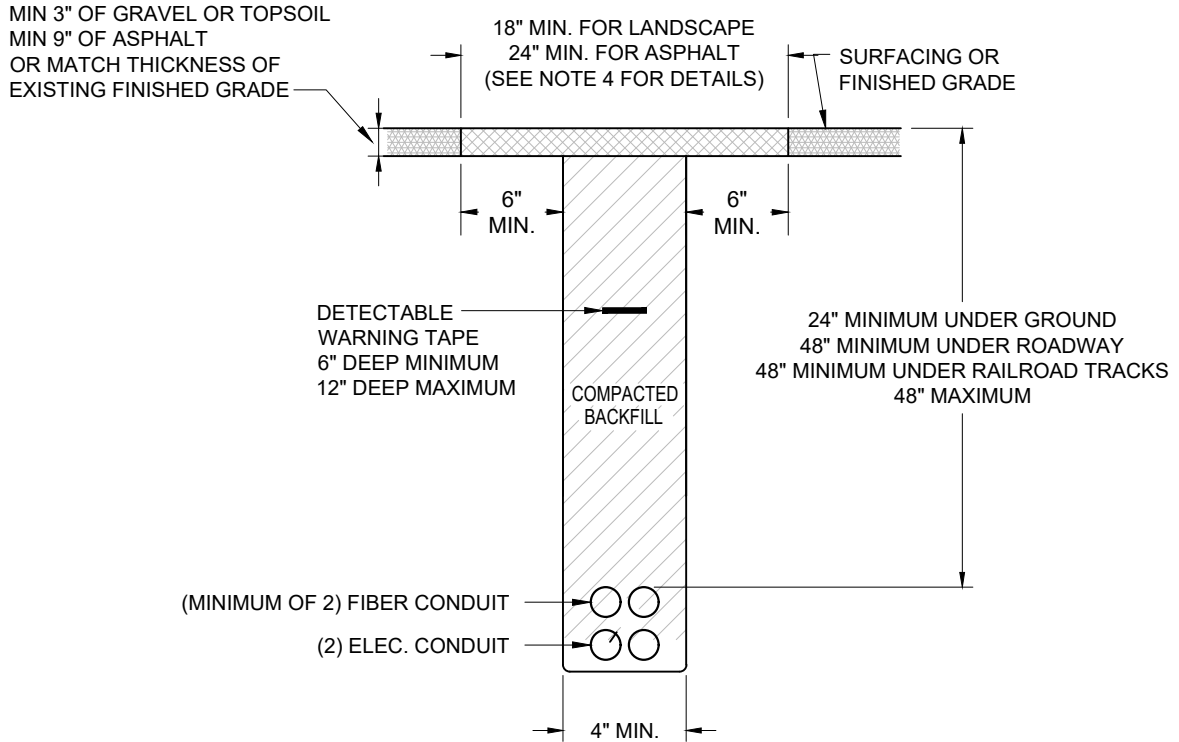

## DETAIL NOTES

1. CONTRACTOR SHALL COORDINATE BORING, DRIVING, OR TRENCHING WITH OTHER UNDERGROUND UTILITIES. CONTRACTOR SHALL USE COMMON TRENCHES WHEREVER POSSIBLE.
2. WHENEVER POSSIBLE, CONDUIT OR CABLE SHALL BE INSTALLED BY BORING, DRIVING, OR ANY OTHER ACCEPTABLE MEANS UNDER CONCRETE UNITS. OPEN CUTTING SHALL BE USED ONLY UNDER SPECIAL CIRCUMSTANCES AND ONLY WITH APPROVAL OF PUBLIC WORKS.
3. MINIMUM WIDTH AND TYPE OF RESTORATION TO BE DETERMINED BY PW INSPECTOR, BASED ON CONTRACTOR'S PRE-ACTIVITY PHOTOS, TO MATCH PRE-EXISTING CONDITIONS.
4. SOD REPLACEMENT SHALL BE A MINIMUM OF 18" IN WIDTH. ASPHALT REPLACEMENT SHALL BE A MINIMUM OF 24" IN WIDTH. CONCRETE REPLACEMENT SHALL BE PER THE DEPARTMENT OF PUBLIC WORKS TRANSPORTATION STANDARD DETAILS 12.3.
5. ANY HARDSCAPE (CONCRETE OR PAVERS) SHALL BE REPLACED IN FULL PANELS OR PAVERS OF THE SAME TYPE, COLOR, AND SIZE AS BEFORE.
6. 1-#12 AWG LOCATE WIRE AND A NYLON OR POLYESTER PULL TAPE WITH 1,250 LBS TEST STRENGTH AND FOOTAGE MARKINGS IN ALL EMPTY CONDUITS.
7. ALL CONDUIT, LANDSCAPE RESTORATION, ASPHALT RESTORATION, AND CONCRETE RESTORATION MUST BE INSTALLED IN ACCORDANCE WITH THE DEPARTMENT OF PUBLIC WORKS TRANSPORTATION STANDARD DETAILS.
8. SEPARATE CONDUIT SHALL BE PROVIDED FOR STREETLIGHT ELECTRICAL CONDUIT, CITY FIBER, SMALL CELL ELECTRICAL CONDUIT AND SMALL CELL CARRIER FIBER.



City and County of Denver  
Department of Public Works

Date:  
April 2018

TYPICAL TYPE 3 COMBINATION POLE CONDUIT  
BURIAL DETAIL

Std. Dwg. No.  
SS-09

# CCD SMALL CELL SPECIFICATIONS

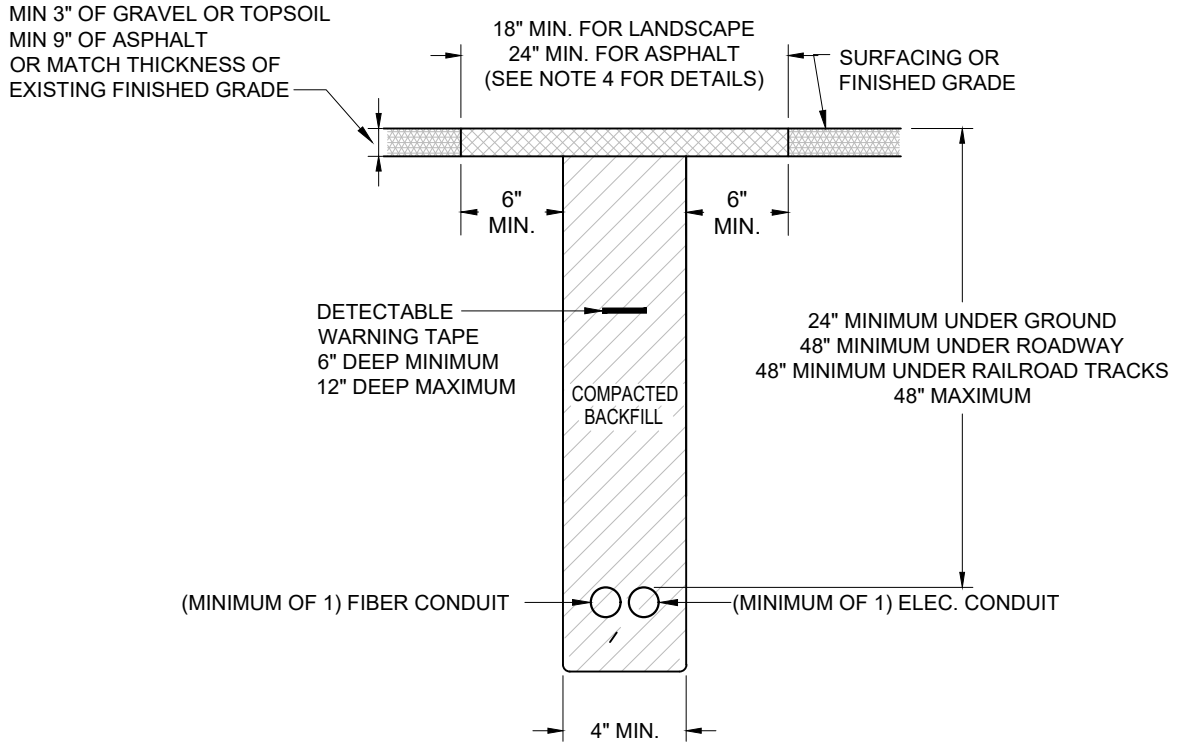

## DETAIL NOTES

1. CONTRACTOR SHALL COORDINATE BORING, DRIVING, OR TRENCHING WITH OTHER UNDERGROUND UTILITIES. CONTRACTOR SHALL USE COMMON TRENCHES WHEREVER POSSIBLE.
2. WHENEVER POSSIBLE, CONDUIT OR CABLE SHALL BE INSTALLED BY BORING, DRIVING, OR ANY OTHER ACCEPTABLE MEANS UNDER CONCRETE UNITS. OPEN CUTTING SHALL BE USED ONLY UNDER SPECIAL CIRCUMSTANCES AND ONLY WITH APPROVAL OF PUBLIC WORKS.
3. MINIMUM WIDTH AND TYPE OF RESTORATION TO BE DETERMINED BY PW INSPECTOR, BASED ON CONTRACTOR'S PRE-ACTIVITY PHOTOS, TO MATCH PRE-EXISTING CONDITIONS.
4. SOD REPLACEMENT SHALL BE A MINIMUM OF 18" IN WIDTH. ASPHALT REPLACEMENT SHALL BE A MINIMUM OF 24" IN WIDTH. CONCRETE REPLACEMENT SHALL BE PER THE DEPARTMENT OF PUBLIC WORKS TRANSPORTATION STANDARD DETAILS 12.3.
5. ANY HARDSCAPE (CONCRETE OR PAVERS) SHALL BE REPLACED IN FULL PANELS OR PAVERS OF THE SAME TYPE, COLOR, AND SIZE AS BEFORE.
6. 1-#12 AWG LOCATE WIRE AND A NYLON OR POLYESTER PULL TAPE WITH 1,250 LBS TEST STRENGTH AND FOOTAGE MARKINGS IN ALL EMPTY CONDUITS.
7. ALL CONDUIT, LANDSCAPE RESTORATION, ASPHALT RESTORATION, AND CONCRETE RESTORATION MUST BE INSTALLED IN ACCORDANCE WITH THE DEPARTMENT OF PUBLIC WORKS TRANSPORTATION STANDARD DETAILS.
8. SEPARATE CONDUIT SHALL BE PROVIDED FOR SMALL CELL ELECTRIC CONDUIT AND SMALL CELL CARRIER FIBER.



City and County of Denver  
Department of Public Works

Date:  
April 2018

TYPICAL TYPE 1, TYPE 2, AND TYPE 4 CONDUIT  
BURIAL DETAIL

Std. Dwg. No.  
SS-10



CCD SMALL CELL SPECIFICATIONS

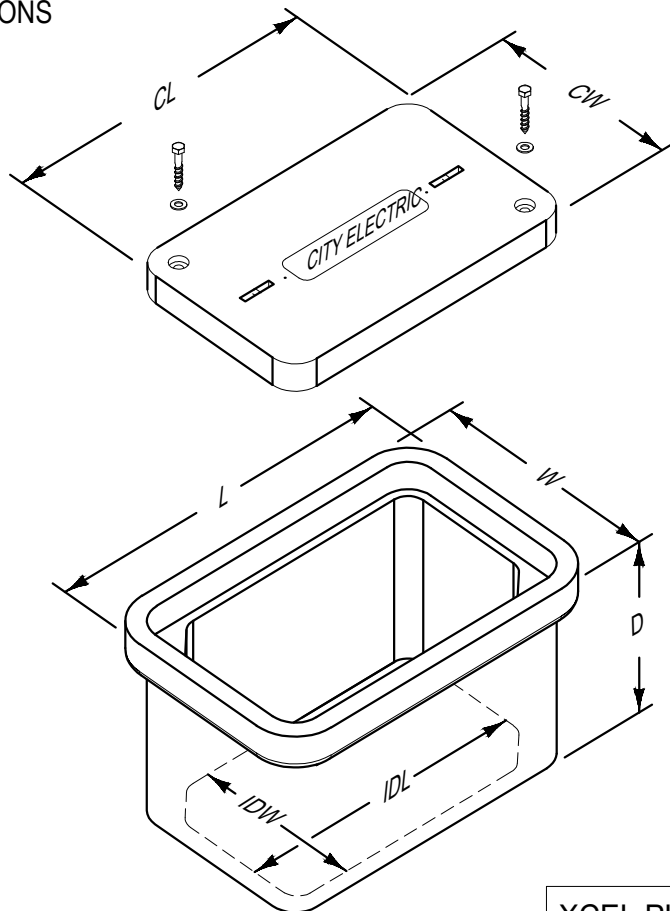

PULL BOX / SPLICE BOX - COMPOSITE MINIMUM DIMENSIONS		
TYPE 1	TYPE 2	TYPE 3
L = 20"	L = 25"	L = 32"
W = 13"	W = 15"	W = 19"
D = 12"	D = 12"	D = 12"
IDL = 17"	IDL = 21"	IDL = 28"
IDW = 10"	IDW = 11"	IDW = 15"
CL = 18"	CL = 23"	CL = 30"
CW = 11"	CW = 13"	CW = 17"

XCEL PULL BOX / SPLICE BOX COMPOSITE MINIMUM DIMENSIONS	
SMALL	LARGE
CAT ID#: LID - 215570 BODY - 215571	CAT ID#: LID - 215567 BODY - 215569
L = 18"	L = 24"
W = 11"	W = 13"
D = 12"	D = 12"

**DETAIL NOTES**

- BOX COVERS MUST BE POLYMER CONCRETE WITH FIBERGLASS REINFORCEMENT, INCIDENTAL TRAFFIC RATED TO TIER 22 AND BOLTED. XCEL ENERGY PULL BOX/SPLICE BOX SHALL BE TIER 8 RATED.
- BOX COVERS SHALL BE LABELED AS FOLLOWS:
  - PULL BOXES CONTAINING STREETLIGHT ELECTRIC SERVICE SHALL BE LABELED "STREETLIGHT"
  - PULL BOXES CONTAINING CITY FIBER SHALL BE LABELED "CITY FIBER"
  - PULL BOXES CONTAINING SMALL CELL CARRIER FIBER SHALL BE LABELED WITH THE NAME OF THE CARRIER. LABELING MUST BE CAST INTO THE COVER AND NOT A SEPARATE INDEPENDENT TAG.
- REFER TO N.E.C. ARTICLE 314 "PULL AND JUNCTION BOXES AND CONDUIT BODIES MINIMUM SIZE" FOR BOX SIZE REQUIREMENTS BASED ON CONDUIT AND WIRE SIZES.
- THE WIRE TERMINATIONS IN THIS BOX SHALL BE MADE USING SUBMERSIBLE INSULATED PEDESTAL LUG CONNECTIONS. PROVIDE ONE MULTI-LUG CONNECTOR FOR EACH PHASE, NEUTRAL AND GROUND CONDUCTOR TO BE SPLICED IN THIS IN-GRADE SPLICE BOX.



City and County of Denver  
Department of Public Works

Date:  
April 2018

PULL BOX / SPLICE BOX TYPICAL DIMENSIONS

Std. Dwg. No.  
SS-11

CCD SMALL CELL SPECIFICATIONS

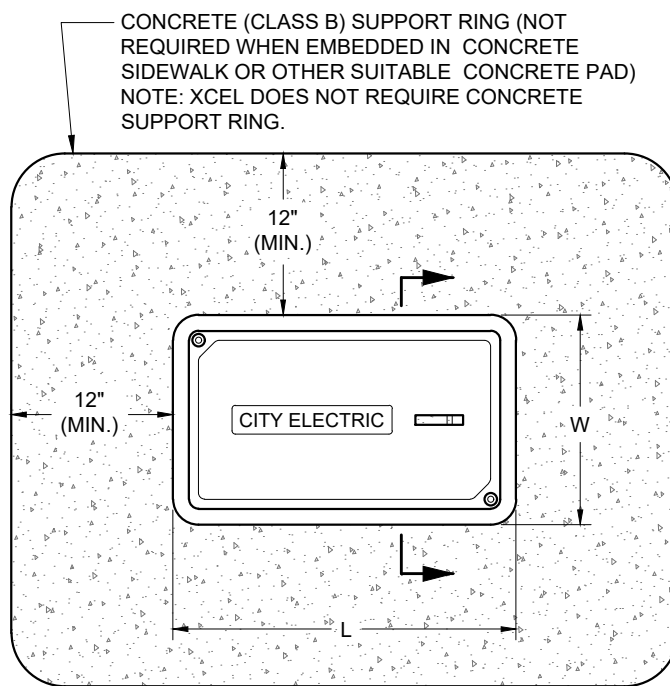

PLAN VIEW

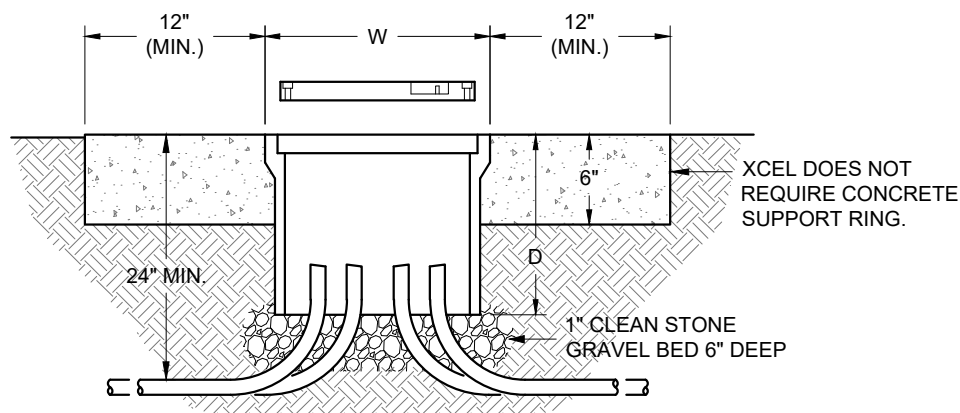

SECTION A-A

TYPICAL PULL BOX / SPLICE BOX

DETAIL NOTES

1. ALL PULL OR SPLICE BOXES SHALL BE INCIDENTAL TRAFFIC RATED TO TIER 22 MINIMUM. XCEL REQUIRES TIER 8 RATED PULL OR SPLICE BOXES.
2. REFER TO SS-11 FOR PULL BOX SIZE REQUIREMENTS.
3. REFER TO SS-13 FOR STREETLIGHT GROUNDING DETAILS.



City and County of Denver  
Department of Public Works

Date:  
April 2018

TYPICAL IN-GRADE PULL BOX / SPLICE BOX DETAIL

Std. Dwg. No.  
SS-12

# CCD SMALL CELL SPECIFICATIONS

## GENERAL NOTES:

1. CITY FIBER AND STREETLIGHT ELECTRICAL SPLICE BOXES MAY NOT BE REQUIRED FOR TYPE 1, TYPE 2, OR TYPE 4 SMALL CELL INSTALLATIONS.

TOP OF FOUNDATION SHALL BE 2" ABOVE ADJACENT SOFTSCAPE WITH 1:1 CHAMFER TOP EDGE, XCEL REQUIRES 4" TO 8" ABOVE SOFTSCAPE.

TIER 22 FLUSH-IN-GRADE POLYMER CONCRETE PULL BOX WITH INCIDENTAL TRAFFIC RATED COVER.

FINAL GRADE

CITY FIBER  
STREETLIGHT ELEC.

2" PVC (MINIMUM)  
CONDUITS IN AND OUT.

2" PVC (MINIMUM), CONNECT TO CIRCUIT AS DESIGNATED ON PLANS.

5/8" DIA. X 8'-0" LG. COPPER CLAD DRIVEN GROUND ROD IN SPLICE BOX 6" (MIN.) AWAY FROM CONCRETE BASE (1' MIN. - 3' MAX. FOR XCEL). EXOTHERMIC WELD OR UNDERGROUND RATED LUG CONNECT CONDUCTOR TO GROUND ROD.

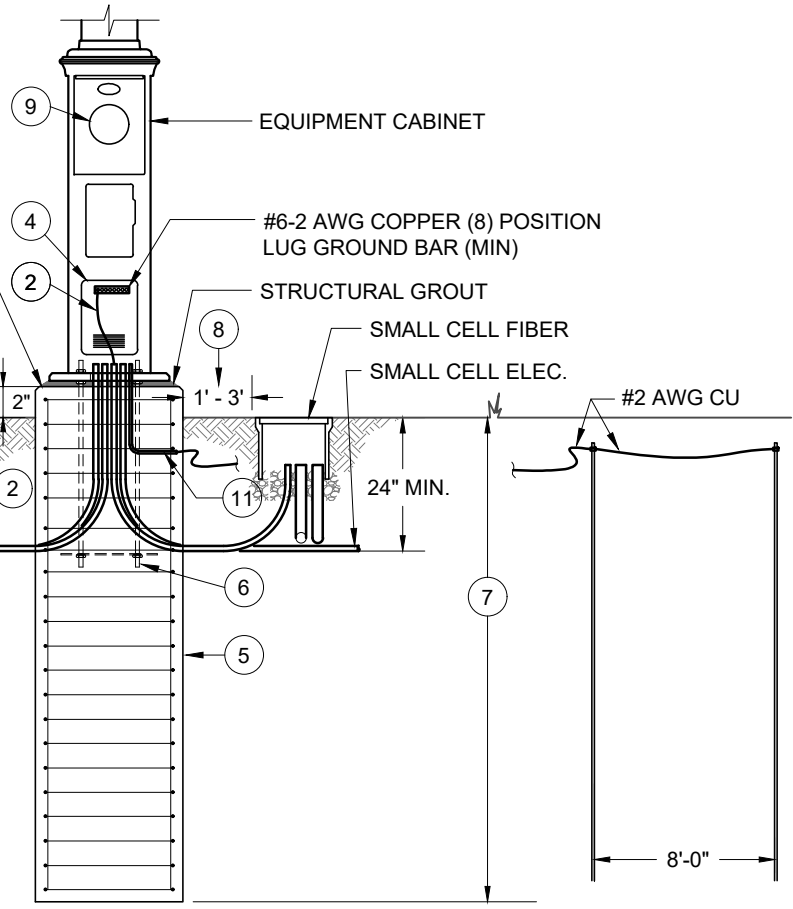

**ELEVATION SECTION VIEW**

5/8" DIA. X 8'-0" LG. COPPER CLAD DRIVEN GROUND ROD (TYPICAL OF 2) 6" (MIN.) AWAY FROM OTHER GROUND RODS. EXOTHERMIC WELD #2 AWG CU CONDUCTOR TO GROUND ROD.

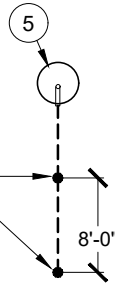

**11** GROUNDING OPTION 1  
LINEAR GROUNDING  
PLAN VIEW

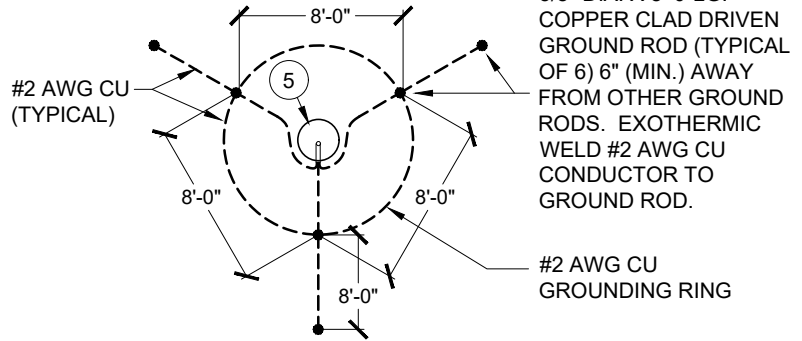

**10** GROUNDING OPTION 2  
RADIAL GROUNDING WITH INNER RING  
PLAN VIEW



City and County of Denver  
Department of Public Works

TYPICAL SMALL CELL ELECTRICAL DETAIL  
IN SOFTSCAPE

Date:  
April 2018

Std. Dwg. No.  
SS-13

# CCD SMALL CELL SPECIFICATIONS

**GENERAL NOTES:**

1. CITY FIBER AND STREETLIGHT ELECTRICAL SPLICE BOXES MAY NOT BE REQUIRED FOR TYPE 1, TYPE 2, OR TYPE 4 SMALL CELL INSTALLATIONS.

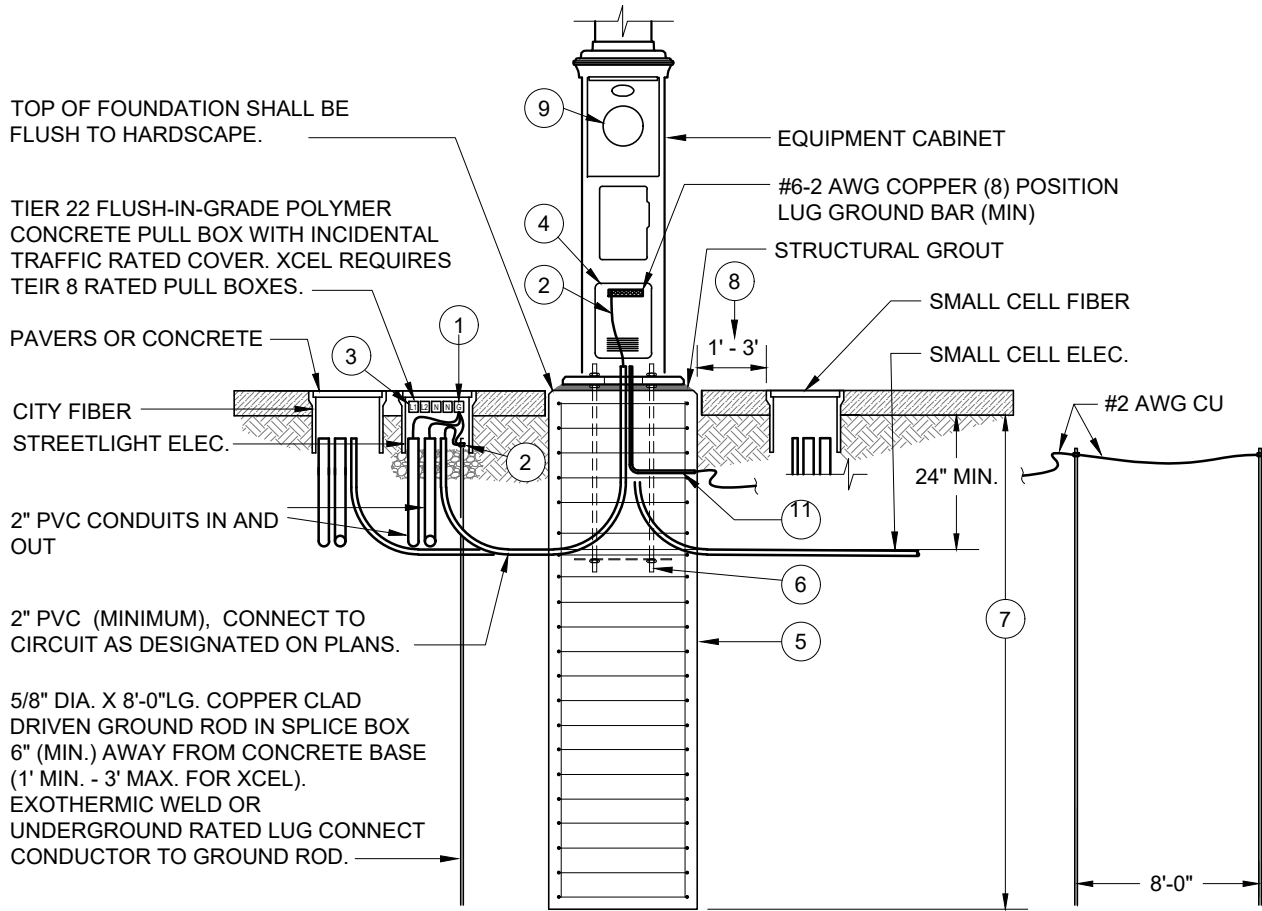

**ELEVATION SECTION VIEW**

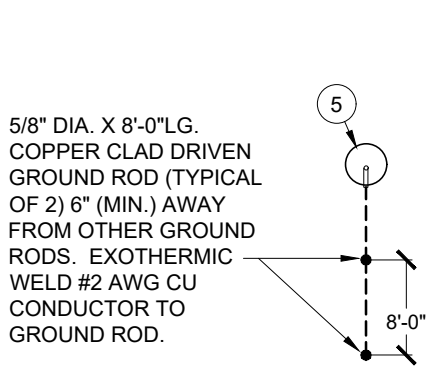

11 **GROUNDING OPTION 1  
LINEAR GROUNDING  
PLAN VIEW**

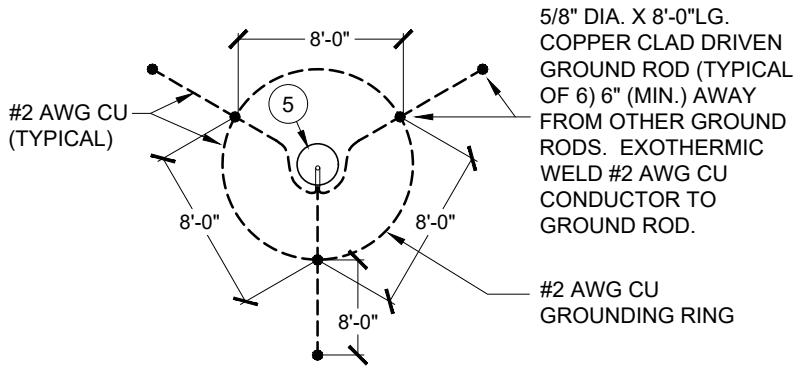

10 **GROUNDING OPTION 2  
RADIAL GROUNDING WITH INNER RING  
PLAN VIEW**

	City and County of Denver Department of Public Works	Date: April 2018
	TYPICAL SMALL CELL ELECTRICAL DETAIL IN HARDSCAPE	Std. Dwg. No. SS-14

# CCD SMALL CELL SPECIFICATIONS

## FOUNDATION DETAIL NOTES

- ① BOND RACEWAY GROUND TO GROUND ROD IN ELECTRICAL PULL BOXES / SPLICE BOXES.
- ② BOND (1#4 SOFT DRAWN BARE CU) TO GROUND ROD IN ELECTRICAL PULL BOXES / SPLICE BOXES AND GROUNDING LUG IN EQUIPMENT CABINET HAND HOLE. XCEL REQUIRES 1#4 CU.
- ③ PROVIDE 3-TERMINAL SUBMERSIBLE UNDERGROUND RATED LUG CONNECTORS TO FIT #14AWG - #4AWG COPPER WIRE, BY BURNDY OR ILSCO NIMBUS OR APPROVED EQUAL. MAXIMUM OF (5) REQUIRED OR (1) FOR EACH CONDUCTOR IN HOME RUN. XCEL REQUIRES 4-LUG TERMINAL FOR HOT CONDUCTORS AND 6-LUG TERMINAL FOR NEUTRAL/GROUND CONDUCTORS, 3-CONNECTIONS MAX. XCEL ALSO REQUIRES #12 AWG, 350 KCMIL CU.AL.
- ④ AT EACH EQUIPMENT CABINET HAND HOLE, PROVIDE A SUBMERSIBLE, WATERPROOF, IN-LINE FUSE HOLDER BY EATON OR APPROVED EQUAL WITH FNQ-R 15A FUSE FOR EACH HOT AND A SUBMERSIBLE, WATERPROOF CONNECTOR ON NEUTRAL (IF REQUIRED).
- ⑤ COMBINATION SMALL CELL (TYPE 3) AND FREE STANDING SMALL CELL (TYPE 4) FOUNDATION EMBEDMENT DEPTH, DIMENSIONS AND REINFORCEMENT SHALL BE PER SS-17 THROUGH SS-20 OR AS DESIGNED BY A STRUCTURAL ENGINEER LICENSED IN THE STATE OF COLORADO.
- ⑥ ANCHOR BOLT CIRCLE SHALL BE 19.5" FOR 16" EQUIPMENT CABINET (OR 23.5" FOR 20" EQUIPMENT CABINET) AND CENTERED ON FOUNDATION WITH AN ANCHOR BOLT TEMPLATE.
- ⑦ DEPTH OF FOUNDATION PER SS-17 THROUGH SS-20 OR AS DESIGNED BY A STRUCTURAL ENGINEER LICENSED IN THE STATE OF COLORADO.
- ⑧ XCEL REQUIRES THE CLOSEST EDGE OF PULL BOX SHALL BE 1' TO 3' FROM FOUNDATION EXCEPT WHEN FIELD CONDITIONS DICTATE OTHERWISE.
- ⑨ XCEL METER SHALL BE PROPERLY GROUNDED PER N.E.S.C. CURRENT ADDITION.
- ⑩ RADIAL GROUNDING OPTION: BOND (1 #2 SOFT DRAWN BARE CU) TO GROUND ROD RING WITH (6) 5/8" x 8'-0" GROUND RODS IN RADIAL DESIGN WITH LOOP RING ON INSIDE (3) RODS. EXOTHERMIC WELD CONDUCTOR TO EACH ROD.
- ⑪ LINEAR GROUNDING OPTION: BOND (1#2 SOFT DRAWN BARE CU) TO (2) 5/8" x 8'-0 GROUND RODS IN LINEAR ARRANGEMENT . EXOTHERMIC WELD CONDUCTOR TO EACH ROD.
- ⑫ PROVIDE 3/4" GRC SLEEVE IN FOUNDATION FOR GROUNDING CONDUCTORS.

## GENERAL NOTE

FOUNDATION DETAILS ARE INCLUDED ONLY TO SHOW ELECTRICAL COMPONENTS. REFER TO SS-17 THROUGH SS-20 FOR STRUCTURAL REQUIREMENTS.



City and County of Denver  
Department of Public Works

Date:  
April 2018

TYPICAL SMALL CELL ELECTRICAL DETAIL NOTES

Std. Dwg. No.  
SS-15

# CCD SMALL CELL SPECIFICATIONS

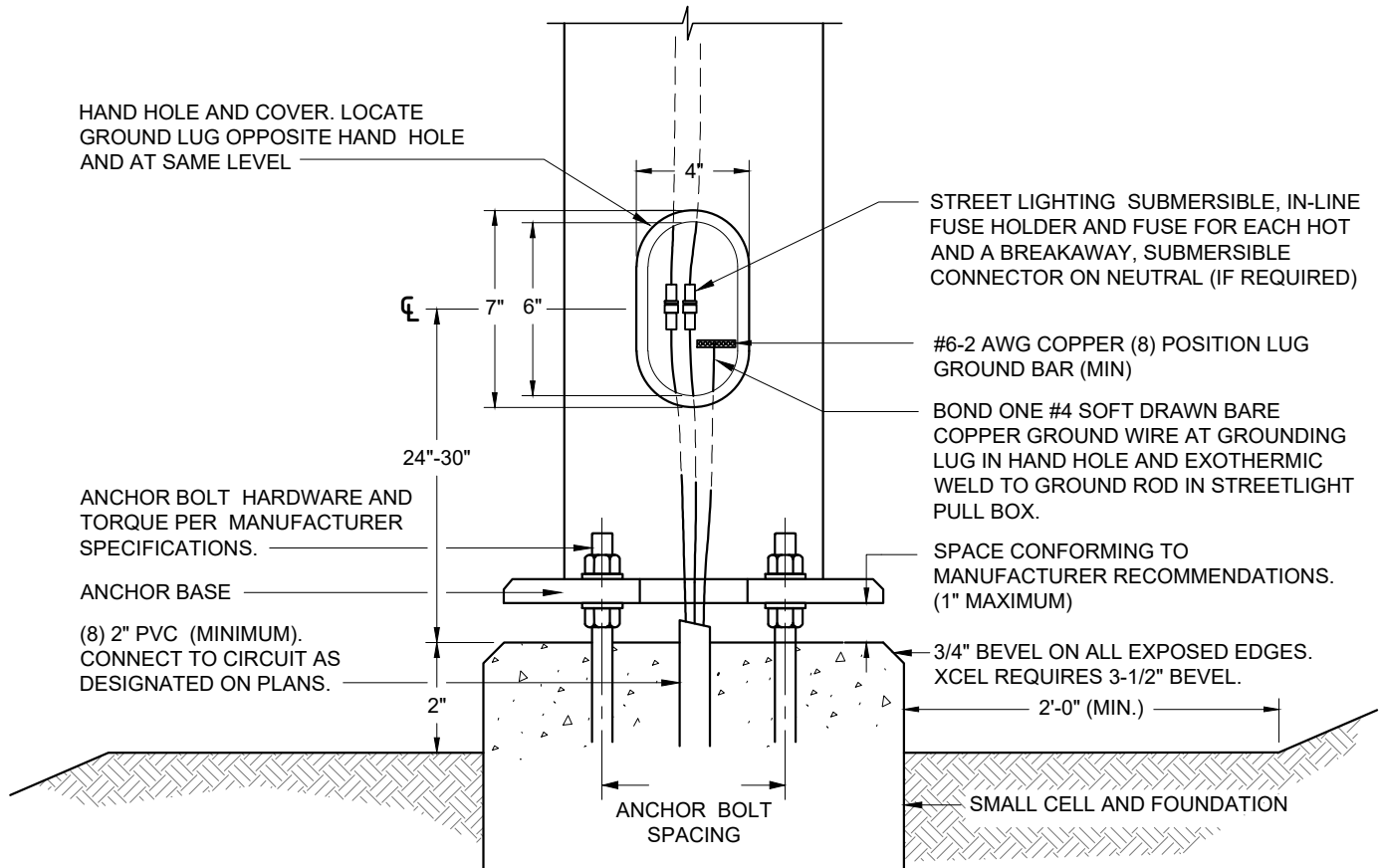

**TYPICAL NON-BREAKAWAY BASE DETAIL**  
FOR USE ONLY OUTSIDE CLEAR ZONE OR IN PROTECTED INSTALLATIONS.

## NOTES

1. SMALL CELL STANDARD FOUNDATIONS SHALL BE PRECAST CONCRETE.
2. ALL CONDUCTORS SHALL BE SIZED IN CONFORMANCE WITH N.E.C. REQUIREMENTS 3/C COPPER #12 AWG CABLE MINIMUM.
3. XCEL REQUIRES SIZE BASED ON THE ODL MANUAL "MAXIMUM DISTANCE AND LUMINAIRES PER STREETLIGHT CONDUCTOR RUN-UG FED" USING ALUMINUM CONDUCTORS.
4. XCEL IS GOVERNED BY THE N.E.S.C. INSTEAD OF N.E.C.
5. ALL EQUIPMENT SHALL BE LOCATED INTERNAL TO THE EQUIPMENT CABINET OR RECESSED IN THE EQUIPMENT CABINET TO MEET UTILITY REQUIREMENTS.
6. EQUIPMENT CABINET SHALL BE SIZED TO HANDLE THE EQUIPMENT REQUIRED BY THE OWNER.
7. EQUIPMENT SHALL BE INSTALLED IN SEPARATED COMPARTMENTS WITH LOCKABLE ACCESS COVER PER OWNER REQUIREMENTS.
8. ANCHOR BOLT CIRCLE SHALL BE 19.5" FOR 16" EQUIPMENT CABINET (OR 23.5" FOR 20" EQUIPMENT CABINET) AND CENTERED ON FOUNDATION. USE ANCHOR BOLT TEMPLATE.



City and County of Denver  
Department of Public Works

Date:  
April 2018

TYPICAL NON-BREAKAWAY POLE BASE  
STANDARD DETAIL

Std. Dwg. No.  
SS-16

# CCD SMALL CELL SPECIFICATIONS

POLE BASE SIZE	CAISSON DIAMETER	CAISSON DEPTH	POLE HEIGHT	BOLT CIRCLE	NO. OF VERT BARS
16"Ø	2'-6"	7'-6"	30'-0" TO 40'-0"	19-1/2"	8
16"Ø	PSE	PSE	>40'-0"	PSE	PSE
20"Ø	3'-0"	8'-0"	30'-0" TO 40'-0"	23-1/2"	12
20"Ø	PSE	PSE	>40'-0"	PSE	PSE

PSE = PER STRUCTURAL ENGINEER (SEE NOTE 3)

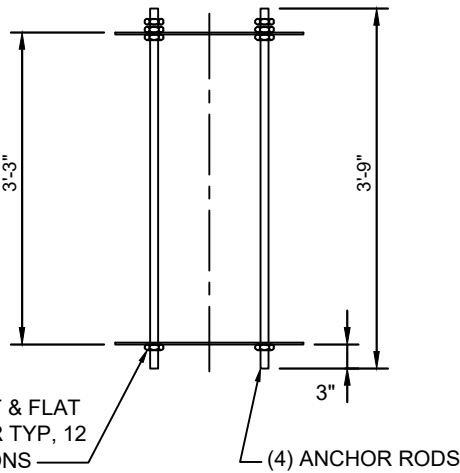
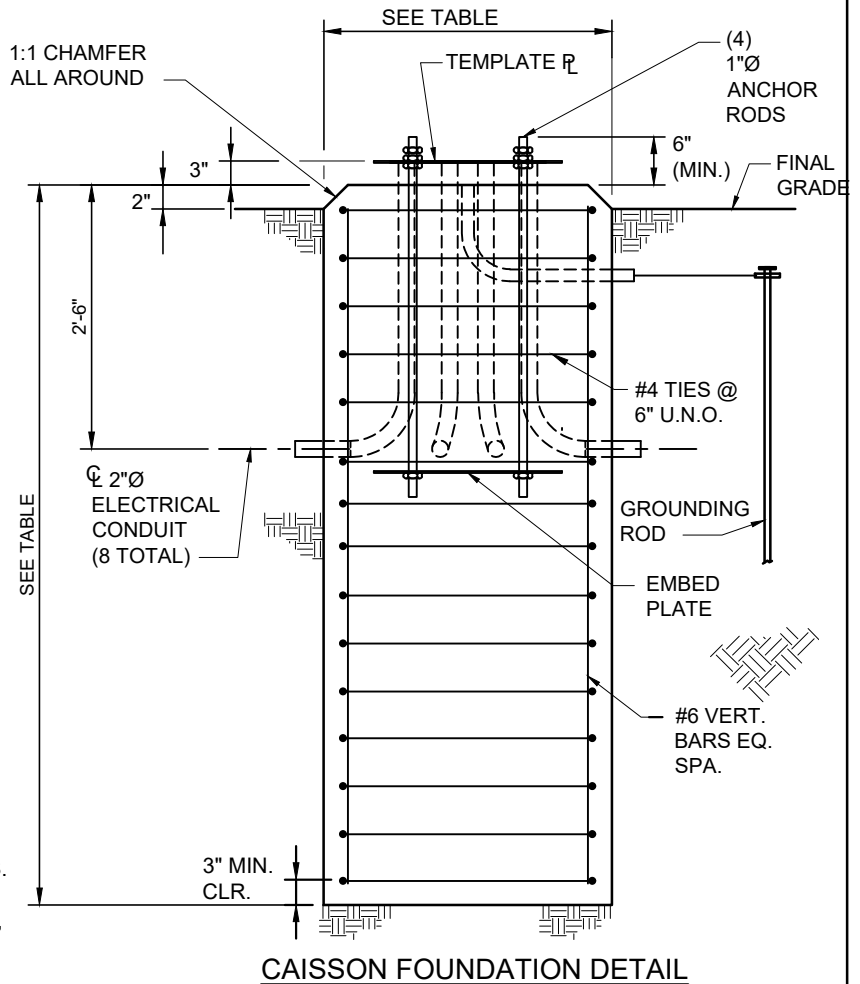
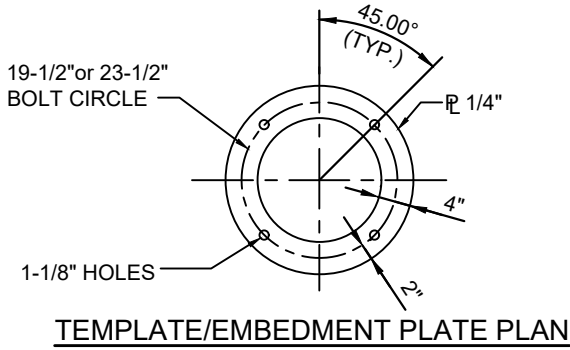
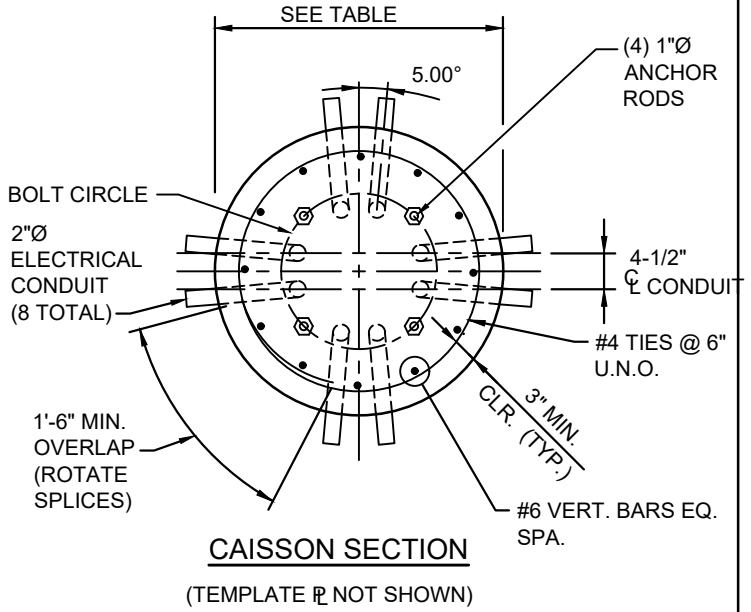

### ANCHOR BOLT DETAIL

1"Ø ANCHOR BOLTS ASTM 1554 GRADE 55 AND SHALL BE GALVANIZED w/HEAVY NUTS, LEVELING NUTS, AND PLATE WASHERS

### NOTES:

- 1) REFER TO SS-13 FOR GENERAL STRUCTURAL NOTES.
- 2) REFER TO SS-04 & SS-05 FOR CONDUIT, ELECTRICAL, AND GROUNDING REQUIREMENTS.
- 3) POLE HEIGHTS GREATER THAN 40'-0" REQUIRE FOUNDATION DESIGN BY CONTRACTOR.



City and County of Denver  
Department of Public Works

TYPICAL FOUNDATION STRUCTURAL DETAIL

Date:  
April 2018

Std. Dwg. No.  
SS-17

# CCD SMALL CELL SPECIFICATIONS

POLE BASE SIZE	PIER DIAMETER	"H"	POLE HEIGHT	BOLT CIRCLE	NO. OF VERT BARS
16"Ø	2'-6"	4'-0"	30'-0" TO 40'-0"	19-1/2"	8
16"Ø	PSE	PSE	>40'-0"	PSE	PSE
20"Ø	3'-0"	5'-0"	30'-0" TO 40'-0"	23-1/2"	12
20"Ø	PSE	PSE	>40'-0"	PSE	PSE

PSE = PER STRUCTURAL ENGINEER (SEE NOTE 3)

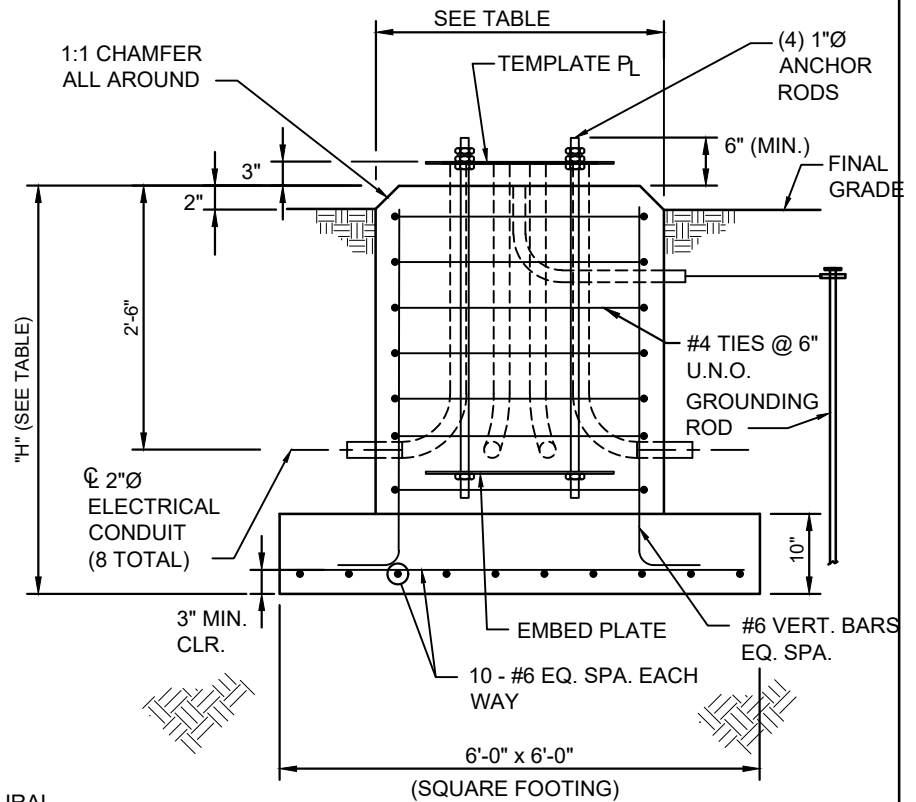
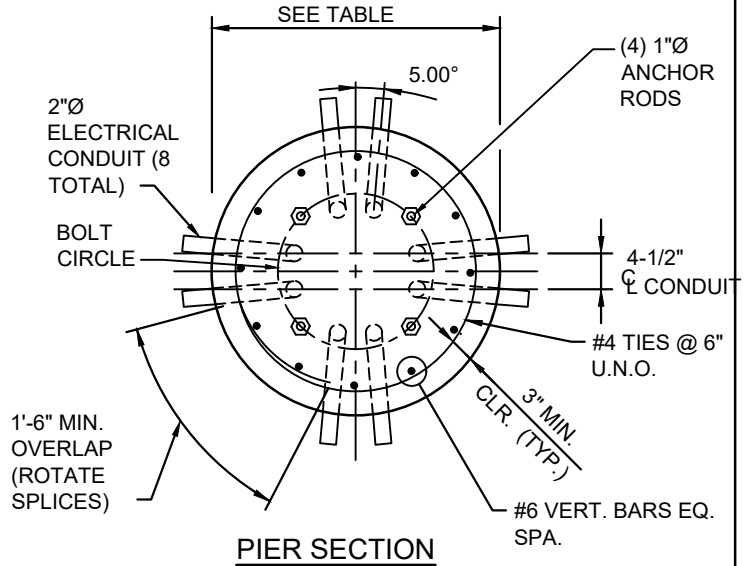

## NOTES:

- 1) REFER TO SS-19 & SS-20 FOR GENERAL STRUCTURAL NOTES.
- 2) REFER TO ELECTRICAL DETAILS FOR CONDUIT, ELECTRICAL, AND GROUNDING REQUIREMENTS.
- 3) POLE HEIGHTS GREATER THAN 40'-0" REQUIRE FOUNDATION DESIGN BY CONTRACTOR.
- 4) REFER TO SS-17 FOR TEMPLATE/EMBEDMENT RING PLAN AND ANCHOR BOLT DETAIL.



City and County of Denver  
Department of Public Works

TYPICAL FOUNDATION STRUCTURAL DETAIL

Date:  
April 2018

Std. Dwg. No.  
SS-18



# CCD SMALL CELL SPECIFICATIONS

## GENERAL STRUCTURAL NOTES:

### 1. DESIGN INFORMATION AND GENERAL REQUIREMENTS

#### 1.1. CODES AND DESIGN GUIDELINES

- A. 2015 INTERNATIONAL BUILDING CODE, WITH CITY & COUNTY OF DENVER (CCD) AMENDMENTS
- B. TIA-222\_G, STRUCTURAL STANDARD FOR ANTENNA SUPPORTING STRUCTURES AND ANTENNAS WITH EXCEPTION OF CCD REQUIREMENTS FOR FROST DEPTH.
- C. AASHTO LRFD SPECIFICATIONS FOR STRUCTURAL SUPPORTS FOR HIGHWAY SIGNS, LUMINAIRES, AND TRAFFIC SIGNALS, FIRST EDITION WITH LATEST INTERIMS
- D. AMERICAN CONCRETE INSTITUTE (ACI) BUILDING CODE REQUIREMENTS FOR STRUCTURAL CONCRETE 318-14.
- E. CITY & COUNTY OF DENVER STREET LIGHTING DESIGN GUIDELINES, MARCH 2017 OR LATEST EDITION.

#### 1.2. LOADS

- A. WIND LOAD SHALL BE 115 MPH ULTIMATE BASED ON ASCE 7-10 SPECIAL WIND REGION.
- B. MAXIMUM DEAD LOAD AT TOP OF FOUNDATION (INCLUDING POLE, POLE BASE, LUMINAIRES, CANTENNA AND EQUIPMENT) IS ASSUMED TO BE 2600 LBS.
- C. TYPICAL RISK CATEGORY WITH MEAN RECURRENCE INTERVAL = 700 YRS (AASHTO)
- D. STRUCTURE CLASS II (TIA)

#### 1.3. GEOTECHNICAL

- A. THE FOLLOWING SOIL PARAMETERS WERE USED FOR STANDARD FOUNDATION DESIGN:
  - 1. LOOSE GRANULAR SOIL WITH A UNIT WEIGHT OF 110 PCF AND A 28 DEGREE ANGLE OF INTERNAL FRICTION (PHI ANGLE).
  - 2. SOFT COHESIVE SOIL WITH A UNIT WEIGHT OF 110 PCF AND A UNIT COHESION OF 500 PSF.
  - 3. PIER AND FOOTING FOUNDATION: COMPACTED FOUNDATION SOIL NET ALLOWABLE BEARING CAPACITY OF 500 PSF WAS USED FOR DESIGN.
- B. CONTACT THE CCD PROJECT REPRESENTATIVE IF ANY OF THE FOLLOWING SOIL CONDITIONS ARE ENCOUNTERED DURING DRILLING/EXCAVATION:
  - 1. THE SOIL HAS A HIGH ORGANIC CONTENT, VOIDS, DELETERIOUS SOILS OR CONSISTS OF SATURATED SOILS.
  - 2. THE SITE WON'T SUPPORT THE WEIGHT OF THE DRILLING RIG.
  - 3. THE FOUNDATION SOILS ARE NOT HOMOGENEOUS.
  - 4. FIRM BEDROCK IS ENCOUNTERED.

#### 1.4. MISCELLANEOUS

- A. CONTRACTOR SHALL VERIFY ALL DIMENSIONS, ELEVATIONS, AND EXISTING CONDITIONS PRIOR TO PROCEEDING WITH THE WORK.

### 2. FOUNDATION NOTES

#### 2.1. GENERAL

- A. HYBRID STANDARD FOUNDATIONS SHALL BE DRILLED CONCRETE CAISSON FOUNDATIONS. THE PIER AND FOOTING FOUNDATION DETAILS PRESENTED IN THESE GUIDELINES PRESENT AN ALTERNATIVE FOUNDATION TYPE THAT MAY BE PROPOSED BY THE CONTRACTOR WITH APPROVAL OF THE CITY & COUNTY OF DENVER.
- B. CAISSON OR PIER AND FOOTING FOUNDATION TYPES MAY BE PROVIDED AS CAST-IN-PLACE CONCRETE OR PRECAST CONCRETE CONSTRUCTION ELEMENTS AT THE OPTION OF THE CONTRACTOR.

#### 2.2. EARTHWORK

- A. DESIGN, FURNISH, AND LEVEL ALL TEMPORARY SHEETING, SHORING, AND DRAINAGE TO MAINTAIN THE EXCAVATION AND PROTECT SURROUNDING STRUCTURES AND UTILITIES.
- B. CAISSON FOUNDATIONS:
  - 1. CAISSONS SHALL BE PLACED AGAINST UNDISTURBED EARTH WITH THE DRILLED HOLE MATCHING THE OUTER DIAMETER OF A CAST-IN-PLACE CAISSON.
  - 2. PRECAST CAISSON FOUNDATIONS SHALL BE DRILLED AT A DIAMETER NO LARGER THAN THE OUTER DIAMETER OF THE CAISSON PLUS 6 INCHES.
  - 3. OVER EXCAVATED AREAS OF THE PRECAST CAISSON SHALL BE BACKFILLED USING A LEAN CONCRETE SLURRY (FLOWABLE FILL) WITH A MINIMUM COMPRESSIVE STRENGTH OF 200 PSI.
- C. PIER AND FOOTING FOUNDATIONS:
  - 1. THOROUGHLY COMPACT BOTTOM OF FOOTINGS PRIOR TO PLACING ANY CONCRETE.
  - 2. BACKFILL SHALL BE COMPACTED TO 95% STANDARD PROCTOR.
  - 3. PRECAST PIER AND FOOTING FOUNDATIONS SHALL BE EXCAVATED SO THAT THE BOTTOM SURFACE IS LEVEL AND COMPACTED TO PROVIDE THE REQUIRED BEARING CAPACITY OF THE UNDISTURBED SOIL.



City and County of Denver  
Department of Public Works

Date:  
April 2018

TYPICAL FOUNDATION STRUCTURAL DETAIL

Std. Dwg. No.  
SS-19

# CCD SMALL CELL SPECIFICATIONS

## GENERAL STRUCTURAL NOTES (CONTINUED):

### 2.3. CAST-IN-PLACE (CIP) OR PRECAST CONCRETE

- A. CONCRETE CONSTRUCTION SHALL BE IN ACCORDANCE WITH ACI 301 "SPECIFICATIONS FOR STRUCTURAL CONCRETE".
- B. CONCRETE MIX DESIGN TO BE IN ACCORDANCE WITH ACI 318, CHAPTER 26 AND THE SPECIFICATIONS INCLUDED IN THESE GUIDELINES.
- C. CONCRETE SHALL BE CLASS B WITH A MINIMUM 28 DAY COMPRESSIVE STRENGTH OF 4500 PSI.
- D. MAXIMUM SLUMP PRIOR TO THE ADDITION OF SUPER PLASTICIZER ADMIXTURES SHALL BE 3 INCHES.
- E. NO CALCIUM CHLORIDE ADMIXTURES OR OTHER AGGREGATES CONTAINING CHLORIDES SHALL BE USED IN ANY CONCRETE.
- F. COARSE AGGREGATE FOR NORMAL WEIGHT CONCRETE SHALL CONFORM TO ASTM C33 SIZE #57.
- G. COLD WEATHER PLACEMENT SHALL COMPLY WITH ACI 306.1.
- H. HOT WEATHER PLACEMENT SHALL COMPLY WITH ACI 305R.

### 2.4. REINFORCEMENT

- A. REINFORCING STEEL SHALL CONFORM TO ASTM A615, GRADE 60.
- B. BARS SHALL BE SECURELY HELD IN ACCURATE POSITION BY SUITABLE ACCESSORIES, TIE BARS, SUPPORT CHAIRS, ETC.
- C. HOOK LENGTHS SHALL BE A MINIMUM 12 BAR DIAMETERS.
- D. CONCRETE COVER FOR REINFORCING SHALL BE AS FOLLOWS:
  - 1. CONCRETE CAST AGAINST EARTH: 3 INCHES.
  - 2. CONCRETE (CIP OR PRECAST) TO BE IN CONTACT WITH GROUND OR WEATHER: 2 INCHES.

### 2.5. ANCHOR BOLTS, ANCHOR EMBED PLATE, NUTS AND WASHERS SHALL BE GALVANIZED IN ACCORDANCE WITH ASTM A153.

### 2.6. ALL FOUNDATIONS SHALL HAVE GROUNDING IN CONFORMANCE WITH THE NEC.



City and County of Denver  
Department of Public Works

Date:  
April 2018

TYPICAL FOUNDATION STRUCTURAL DETAIL

Std. Dwg. No.  
SS-20



Refer to Appendix B for small cell infrastructure specifications.

## B SPECIFICATIONS

The following sections describe in detail the foundation and electrical specifications. All work completed in the ROW must be in accordance with the City and County of Denver (CCD) Public Works Transportation Standards and Engineering Details.

### B.1 Small Cell Pole

#### Description

This work consists of furnishing and installing foundations, small cell poles, conduit, junction boxes, cable, wiring, junction boxes, and incidental materials for small cell installation in accordance with these specifications and in conformance with the details, lines, grades, and locations shown on the plans.

#### Materials

Small Cell materials shall conform to Small Cell and Electrical Materials.

- a) *Foundations.* Concrete bases and equipment pads shall be pre-cast or cast-in-place concrete per the City standard to meet ACI 318. A complete foundation includes the concrete, reinforcing steel, anchor bolts, leveling nuts, conduit stubs, ground rod and wire, excavation and backfill, restoration, accessories as required to provide a complete unit. Banner arm (if required) wind loading shall be incorporated into light standard structural design.
- b) *Small Cell Standard.* A complete light standard includes the metal upper pole, mounting bracket, mast arm(s), cantenna, equipment cabinet, base, grounding system, and all hardware. The upper pole shall have a handhole at the top to maintain City fiber and streetlight electrical service. An optional handhole shall be provided at the bottom of the upper pole if fiber and electrical service cannot be accessed from the equipment cabinet.

Pole and mast arm or arms shall be the type and size shown on the plans.

- c) *Conduit.* Conduit includes conduit, trenching, backfill, jacking, augering, fittings, drainage tees, sealing, restoration, and accessories as required to provide a complete installation.

- d) *Electrical Warning Tape.* Detectable electrical warning tape shall consist of pre-manufactured non-adhesive polyethylene material that is unaffected by acids, alkalines, and other soil components. The color of the tape shall be red, and it shall be, at a minimum, 3.5 mils thick and 6 inches wide. Its tensile strength shall be 2,500 psi lengthwise.

The electrical tape shall include the following identification printed in black letters continuously along the length of the tape: "CAUTION BURIED ELECTRIC LINE BELOW".

The identification note and color of tape shall conform to the requirements of the "American Public Works Association (APWA) Uniform Color Codes (Red) – Electrical Power Lines, Cables, Conduit and Lighting Cables."

- e) *Conductors.* Conductor includes control wiring, luminaire wiring, main circuit wiring, ground wiring, service entrance wiring, pulling, splicing, connections, testing, and all other wiring necessary for a complete installation.
- f) *Pull boxes.* Pull box includes pull box, cover with bolts, excavation, gravel base, backfill, sealing, restoration, and accessories as required to provide a complete installation.
- g) *Materials List.* At the preconstruction conference the Contractor shall submit to CCD three copies of a list of all materials and equipment to be incorporated into the work. The Contractor shall include the following items on the list:
- a. Small cell standards
  - b. Pull Box
  - c. Fuse holders
  - d. Conductors
  - e. Conduit
  - f. Wireless Lighting Control and Monitoring System
  - g. Small cell foundations
  - h. Equipment pads
  - i. All other items required for a complete installation

CCD will return lists that are incomplete or that include unacceptable materials to the Contractor for correction and re-submission.

The Contractor shall not order materials or equipment until CCD and the party or agency responsible for maintenance have reviewed and approved the materials and equipment list. CCD's approval of the list shall not relieve the Contractor responsibility for the proper functioning of the completed installation.

- h) *Technical Support.* During the warranty period, technical support shall be available from the manufacturer via telephone within 24 hours of the time the call is made from the Contractor, and this support shall be made available from factory certified personnel or factory certified installers at no additional charge to the City and County of Denver.

## General

All work shall conform to these specifications and the National Electrical Code (NEC) when the small cell pole is owned by CCD or the Carrier, or the National Electrical Safety Code (NESC) when the small cell pole is owned by Xcel Energy.

The Contractor and/or Network Provider shall keep fully informed of and comply with all Federal, State, and local laws, ordinances, and regulations, and all orders and decrees of bodies or tribunals having any jurisdiction or authority, which may affect those engaged or employed on the work, or affect the conduct of the work. The Contractor and/or Network Provider shall protect and indemnify the City and County of Denver and its representatives against any claim or liability arising from or based on the violation of any such law, ordinance, regulation, order or decree, whether by the Contractor and/or Network Provider, the subcontractors, suppliers of materials or services, or their employees.

Each system shall be installed as shown on the plans or as designated. The Contractor and/or Network Provider shall furnish and install all incidentals necessary to provide a complete working unit or system.

### Concrete Foundation Pads and Small Cell Standard Foundations.

Foundations shall be installed as shown on the plans, complete with grounding. The Contractor and/or Network Provider shall test and report soil conditions to CCD as necessary to ensure proper installation of foundations. Foundations shall be installed at the final grade.

All anchor bolts shall be positioned by means of steel templates. The center of the template shall coincide with the center of the foundation. Anchor bolt size and 19.5-inch bolt circle shall accommodate a 16-inch equipment cabinet per manufacturer's requirements. Anchor bolt size and 23.5-inch bolt circle shall accommodate a 20-inch equipment cabinet per manufacturer's requirements.

All small cell standard foundations shall be as detailed.

Conduits shall be properly positioned and anchored before the concrete is placed.

Coordinate the base setback and orientation with CCD.

All foundations shall have ground rods conforming to the NEC or NESC. All foundations on structures shall be grounded to the structural steel by a method that is in accordance with the NEC or NESC and which is approved by CCD.

### Small Cell Standards

Poles, equipment cabinets, and bolts shall be galvanized stainless steel. Galvanizing will be performed in accordance with ASTM 123 and meet the following galvanization and paint requirements.

1. Galvanizing will be SSPC-SP1 Solvent wiped where needed and the Galvanizing will receive a sweep blast to a uniform dull appearance. Any areas of fracture will be repaired. Any excess zinc build up should be blended to no higher than the height of a dime with no thick edges or areas that may cause paint entrapment potentially leading to a premature coating failure.

The first epoxy coat typically should be applied within 120-180 minutes of abrasive blasting. Items shall be cleaned free of blast debris before coating. Compressed air should be used to clean items; items should be free of Oil, residue, and any other contaminates/debris.

- Epoxy Primer Gray- B107989EA80K-A
- Impact Resistance Direct 100 IN/LBS @ 2.0-3.0 Mils (ASTM D2794)
- Impact Resistance Indirect- 100 IN/LBS @ 2.0-3.0 Mils (ASTM D2794)
- Cross- Hatch Adhesion 5B (ASTM D3359)
- Conical Mandrel 1/8" (ASTM D522)
- Pencil Hardness 2H (ASTM D3363)
- Specific Gravity 1.58 +/- 0.05 G/ML
- Theoretical Coverage 121.63 ft<sup>2</sup>/LB @ 1.0 Mil
- 60 percent gloss 75-85 (ASTM D523)

The Epoxy prime coat shall be applied on poles for an DFT Average of 5.0 Mils for the bottom eight feet, 3.0 Mils DFT above that. Arms have the epoxy prime applied for a 3.0 mil DFT. DFT readings shall be taken in accordance with SSPC-PA2.

Top coat to be applied for an DFT of 3.0 mils average unless noted otherwise.

Aerosol touch up should used for coverage on areas that were masked by a hanging device (Hanging hook or chain, etc) or used to repair small scratches or imperfections.

Poles shall be set plumb, and centered, on the small cell standard foundation using leveling nuts when installed.

Defects and scratches on painted, powder-coated, or anodized poles shall be primed and painted with a color-matched paint to match undamaged pole sections. Defects and scratches on galvanized poles shall be re-galvanized in the field.

Stainless steel mounting hardware shall be used to mount luminaires, mast arms, access doors, antenna, equipment cabinet, and other hardware to the poles. Apply an approved zinc-based anti-seize compound to all mounting hardware prior to assembly.

Banner arms (if required) shall be incorporated into small cell standard structural design.

## Conduit

The electrical conduit system shall be installed in accordance the following:

In the conduit system, the locations of conduit, junction boxes, and expansion joints shown on the plans are approximate. Actual locations shall be established during construction. The conduit system shall be located to avoid interference with known present or known construction installations. All underground conduit runs and conduit risers on poles shall be installed as needed even though they may not be shown on the plans.

All conduit shall be installed within the public Right of Way and shall be at least two-inch (2" minimum) inside diameter unless otherwise designated on the plans. The Contractor and/or Network Provider may use larger conduit than specified. If larger conduit is used, it shall be for the entire run from outlet to outlet. Reducer couplings shall not be used. Larger conduits shall be sized to accommodate the constraints established by the hole in the pole anchor base plate.

Conduit terminating in standards or pedestals shall extend approximately two inches past the foundations and shall slope toward the junction box opening. Conduit entering pull boxes shall terminate two inches inside the box wall and two to five inches above the bottom, and shall slope toward the top of the box to facilitate pulling of conductors. Conduit entering through the bottom of a pull box shall be located near the end walls to leave the major portion of the box clear. At all outlets, conduits shall enter from the direction of the run.

The ends of all conduits, whether shop or field cut, shall be reamed to remove burrs and rough edges. Cuts shall be made square and true so that the ends will butt or come together for their full circumference.

Non-metallic conduit shall be cut with a hacksaw or other approved tool. Non-metallic conduit connections shall be the solvent-weld type.

Conduit connections at junction boxes shall be tightly secured and waterproofed. All conduit ends shall be sealed with duct seal after installation of wiring. The duct seal shall be rated for outdoor use.

When specified, conduit shall be installed under existing pavement by boring operations. Where plans show that existing pavement is to be removed, jacking the conduit is not required. Jacking or drilling pits shall maintain a minimum of two feet clear of the edge of pavement. Water shall not be used as an aid in the jacking or drilling operations.

Trenching shall be in conformance with CCD standards. Backfill shall be per CCD standards.

Detectable red electrical warning tape shall be installed between six inches and 12 inches below finished grade for all underground conduit runs.

Underground conduit shall be buried a minimum of two feet below finished grade. There shall be no sag between boxes. Conduit within the public ROW shall be buried 48 inches (maximum) below finished grade.

Junction Boxes shall be placed at conduit ends, at all locations where conduit bends in a single run would equal 360° or greater per NEC requirements, and at all other locations shown on the plans. The Contractor may install additional pull boxes to facilitate the work.

Excavate minimum 24 inches below base depth of each junction box, backfill and compact with pea rock to permit draining of water.

Placement and setback of the junction boxes shall be coordinated with CCD.

Unless otherwise shown on the plans or directed by CCD, junction boxes shall be installed so that the covers are level with the sidewalk grade. Covers shall be flush with the surrounding finished ground when no grade is established.

Where a conduit stub-out is called for on the plans, a sweeping elbow shall be installed in the direction indicated. All conduit stub outs shall be capped.

## Wiring

All wiring shall be copper, 600 Volt rated, Type: Conform to the applicable UL and ICEA Standards for the use intended. Copper conductors with 600-volt insulation unless otherwise specified or noted on the drawings. Stranded conductors for No. 8 and larger, with the exception of the ground rod conductor shall be #6 AWG solid, bare, copper.

Aluminum Conductors Prohibited: Aluminum conductors will not be permitted.

Insulation: Type THWN/THHN insulation minimum unless otherwise specified or noted on the drawings.

Size: No. 12 minimum unless otherwise specified or noted on the drawings. Not less than NEC (NESC if Utility owned) requirements for the system to be installed.

Color Coding: Phase, neutral and ground conductors color-coded in accordance with NEC (NESC if Utility owned). Connect all Conductors of the same color to the same phase conductor as follows:

208Y/120V-3PH-4W Color coding shall be:

- 1) Phase = Black
- 2) Phase = Red
- 3) Phase = Blue
- 4) Neutral = White
- 5) Ground = Green

120/240V-1PH-3W Color coding shall be:

- 1) Line 1 = Black
- 2) Line 2 = Red
- 3) Neutral = White
- 4) Ground = Green

Unless otherwise authorized, the multiple system of electrical distribution shall be used. Conductors of the size and material specified shall be installed for control wiring, luminaire wiring, small cell equipment wiring, City IOT wiring, main circuit wiring, ground wiring, service entrance wiring, and all other wiring necessary for a complete installation.

Conductors shall be sized to prevent a voltage drop of more than three percent per feeder run. All conductors shall be installed in conduit.

All power and lighting circuits shall include an insulated green grounding conductor.

A complete grounding system shall be installed for the entire lighting installation. Grounding shall consist of ground cables, conduits, grounding rods, wire or strap, and ground fittings, as required by the NEC (or NESC if Utility owned).

Type THWN conductors shall be used for all underground conduit runs. Leave sufficient lengths of branch conductors to allow conductor splices to be extracted from pole base for maintenance. Type XHHW shall be used for the service entrance conductors.

Extend three conductor SOW cable feeder leads to the luminaires from the cables in the pole base.

Install in-the-line fuses on each feeder lead. Leave sufficient lengths of feeder conductors to allow fuses and conductors to be extracted from pole base for maintenance.

Provide a No. 6 AWG solid, bare, copper wire connection to ground rod with ample length to allow connection to light standard, and system ground conductor.

Attach grounding conductor to the energy suppliers neutral at the service point. Terminate grounding conductor with less than 25 ohms ground reference at the service point. If ground resistance is greater than

25 ohms, add additional ground rod(s) or other ground reference bond to bring the resistance to under 25 ohms resistance to earth. Provide ground rods elsewhere as shown on the drawings.

Butt splices within the bases are not acceptable.

At each pole, provisions shall be made for convenient sectionalizing of the circuits. This shall be done by providing ample length (18 to 24 inches) of branch conductor ends and performing splices using submersible type (Burndy Uni-tap connectors or an approved equal). Wire nuts are not an acceptable method for splicing. Splicing shall only be performed within the pole bases and splice boxes where applicable.

Separation of service shall be provided within the pole by conduit or dividers. Electrical wiring and fiber shall be separated by Owner within.

### Testing

Prior to final acceptance, the Contractor and/or Network Provider shall demonstrate to CCD's satisfaction that all electrical and lighting equipment installations are in proper working condition. Temporary power and all cable connections required for testing shall be provided by the Contractor and/or Network Provider.

The Contractor and/or Network Provider shall perform grounding tests to show ground resistance of 25 ohms or less.

### As-built Drawings and O&M Manual

Contractor shall supply accurate as-built drawings of the project to CCD. Drawings shall indicate location and setback of conduit, lighting control center, and utility service point, and pole locations along the roadway measured from a reliable location.

The Contractor shall collect, gather and assemble into one book the installation details, instructions, schematics of actual equipment and operations directions supplied by the manufacturer with all equipment. Final acceptance of the work will be withheld until such data has been presented complete to CCD. The manual shall be available for instruction of operations and maintenance of the equipment and systems.

### Method of Measurement

Concrete bases and equipment pads will be measured by the actual number installed and accepted.

Small cell standards will be measured by the number of small cell standards installed and accepted. Measure each type separately as described on the Plans.

Luminaires will be measured by the number of luminaires installed. Measure each type separately as described on the Plans.

Lighting control centers will be measured by the number installed.

Conduit will be measured by the linear foot in place. Measure each type separately.

Wiring will be measured by the linear foot in place. Measure each type separately.

### Basis of Payment

The accepted quantities will be paid for at the contract unit price for each of the pay items listed on the plans and as they appear in the bid schedule. All associated work items will be considered incidental.

**Table 0-1: Example Pay Items and Units**

Pay Item	Pay Unit
Small Cell Standard Metal (___ foot)	Each
Luminaire (Type)(LED)(Lumens)	Each
Luminaire (Type)(LED) Special	Each
___ Inch Electrical Conduit	Linear Feet
___ Inch Electrical Conduit (Plastic)	Linear Feet
___ Inch Electrical Conduit (Bored)	Linear Feet



Wiring	Linear Feet
Lighting Control Center	Each
Secondary Service Pedestal	Each
Pull Box	Each
Standard Foundation	Each
Concrete Foundation Pad	Each

When the Contractor and/or Network Provider, at his/her option, installs larger conduit than specified, it will be paid for at the original contract price for the size specified.

The following items will not be measured and paid for separately, but shall be included in the work:

- 1) Soil testing for foundations.
- 2) Pull wire, weatherheads, and adaptors and expansion joints for conduit
- 3) Additional pull boxes installed at the Contractor's and/or Network Provider's option.
- 4) Saw cutting; trenching; excavation; backfill; jacking; drilling pits; underground electrical warning tape; removal of pavement, sidewalks, gutters, and all other work necessary to complete conduit installation.
- 5) Electrical conductor tagging.
- 6) Testing of the installation, including temporary power and all required cable connections.

END OF SECTION

## B.2 Small Cell Materials

### General

Materials shall be of a standard line from a name brand manufacturer or as specified in this document. Electrical material shall be listed by the Underwriters' Laboratories, Inc. (UL), and shall conform to the National Electrical Code (NEC) when the streetlights are owned by CCD, or the National Electrical Safety Code (NESC) when the streetlights are owned by the Utility.

Material shall be the same as, or compatible with, that used and accepted by the agency responsible for maintenance.

CCD may inspect all lighting material and all electrical materials and all other materials and accept or reject them at the project site. Samples may be taken or manufacturer's certifications may be accepted in lieu of samples.

### Concrete Bases and Concrete Equipment Pads

Concrete shall be Class B.

Anchor bolts shall be designed by the Contractor's and/or Network Provider's Engineer or as shown on the working drawings. The threaded ends of the anchor bolts, the nuts, and the washers shall be galvanized in accordance with ASTM A153.

Reinforcing steel shall conform to Section 0.

### Small Cell Standards

- a) *General.* All structural components of small cell standard, base, equipment cabinet, couplers, anchor bolts, luminaires, cantenna, and other attachments to be used shall be designed for a minimum of 115 MPH wind velocity, in accordance with AASHTO's *Standard Specifications for Structural Supports for Highway Signs, Luminaires, and Traffic Signals*, TIA-222 rev G and ASC 710 with IBC 2012 (or latest standard). Foundations shall meet ACI 318-11 and ACI 318-14.
- b) *Metal Small Cell Standards.* Metal small cell standards shall be fabricated of steel unless otherwise approved by CCD. Whenever Small Cell Standard Metal is specified, the Contractor and/or Network Provider shall furnish galvanized steel. The Contractor and/or Network Provider may furnish aluminum small cell standards if CCD gives approval. Material type and shape of small standards shall be the same throughout the design district, unless otherwise approved by CCD.

All standards shall have weatherproof cable-entrance grommets located in conformity with the type of mounting used. Metal surfaces shall be free of imperfections marring the appearance and of burrs or sharp edges that might damage the cable.

All metal poles shall be straight and shall be supplied with pole caps when applicable.

Steel mast arms shall be made of Schedule 40 standard steel pipe conforming to ASTM A 53.

All steel poles, mast arms and base flanges shall be hot-dip galvanized in accordance with ASTM A 123. Units on which the spelter coating has been damaged shall be repaired as provided in AASHTO M 36, or other approved method.

Base flanges for steel poles shall have continuous welds both inside and outside, unless otherwise permitted. Base flanges inserted into the pole and bonded shall meet the requirements for materials and strength stated herein.

Each metal standard shall be wired with a breakaway fused connector of proper capacity rating. The fused connector shall be located in the equipment cabinet. If the light standard has no equipment cabinet, the fused connector shall be located in the pole at the hand hole.

All equipment cabinets or bases shall have vandal resistant, removable access doors.

Hardware used with steel standards shall be either cadmium plated steel, hot dip galvanized steel, or stainless steel.

## Conduit

Unless otherwise specified, conduit shall be rigid non-metallic electrical conduit currently recommended and approved by Underwriters' Laboratories, Inc. for the proposed use conforming to ASTM-F 441 schedule 40, (Schedule 80 or bored HDPE where installed under roadways). Fittings shall be the type used outside the conduit and PVC cement welded. Submersible fittings shall connect the conduit in a manner that makes the joints watertight.

All in-grade Pull Boxes shall be polymer concrete, bottomless and tier 22 rated bolted covers. 13 inches by 24 inches and 18 inches deep manufactured by Quazite; Cat. # PG1324BA18, unless otherwise noted on the plans. Covers shall be Cat. # PG1324HH00 with stainless steel bolts and the word "ELECTRIC" molded into the top.

## Wiring

Conductors shall be standard copper with 600-volt insulation, type THWN or XHHW for underground installation in conduit, and for aboveground installation within poles and service cabinets. The size and type shall be as shown on the plans.

## Fuses

Each luminaire in the 120-volt system shall be fused with one 6-amp fuses. Fuse connectors shall be installed in the phase wires of their respective circuits at the pull box located adjacent to the light standards or in the pole base. The fuses shall be mounted in inline single-pole molded fuse connector/holders. The fuse holders shall be a DOT-PLUG (Catalog No. Duraline-16998), or approved equal. Fuses shall be of the breakaway type. The Contractor shall provide sufficient excess conductor length to allow withdrawal of the connected fuse holder. The grounding wires shall not be fused. Fuses and fuse holders shall be "UL" listed and shall be installed in such a manner that the fuse stays with the load side when holder is separated. In addition, the Contractor shall form loops in the leads on each side of the fuse holders and so position the fuse holders so that they may be easily removed or inserted through the opening at top of pull box.

## Secondary Service Pedestals

The service cabinet shall include all equipment necessary to connect to the energy provider's overhead secondary conductors or transformer.

All-In-One commercial meter/power pedestal and non-metered/power pedestals shall meet or exceed City and County of Denver Standards.

END OF SECTION

## B.3 Moisture and Density Control

### Construction of Moisture and Density Control Areas

Maximum dry density of all soil types encountered or used will be determined in accordance with AASHTO T 99, AASHTO T 180, or a modification thereof.

The amount of water to be used in compacting A-2-6, A-2-7, A-4, and A-6 through A-7 soils shall not deviate from optimum on the dry side by more than two percentage points as determined by AASHTO T 99, T 180, or a modification thereof, as designated in the Contract. A-4 soils which are unstable at the above moisture content shall be compacted at a lower moisture content to the specified density. The amount of water used in compacting all other soils shall be as required to obtain the percent relative compaction required.

**Table 0-2: Soil Compaction**

Soil Classifications (AASHTO M 145)	AASHTO T 99			AASHTO T 180		
	Minimum	Relative	Compaction	Minimum	Relative	Compaction
	(Percentage)			(Percentage)		
A-1	100			95		
A-3	100			95		
A-2-4	100			95		
A-2-5	100			95		
All Others	95			90		

Additional work involved in drying backfill material to the required moisture content shall be included in the contract price paid for electrical conduit with no additional compensation.

The percent of relative compaction specified shall be equal to or greater than minimum values as shown in the following table for the various classes of soil and type of compaction.

END OF SECTION

## B.4 Structural Concrete

### Description

This work consists of furnishing and placing portland cement concrete in accordance with these specifications and in conformity with the lines, grades and dimensions as shown on the plans.

### Classification

The classes of concrete shown in Table 0-3 shall be used when specified in the Contract.

Table 0-3: Concrete Table

Concrete Class	Required Compression Strength (psi)	Field	Cementitious Content: Minimum (lbs/yrds <sup>3</sup> )	Material Range	Air Content: % Range (Total)	Water/Cementitious Material Ratio: Maximum or Range
B	4500 at 28 Days	N/A			5 – 8	0.45
D	4500 at 28 Days		615 to 660		5 – 8	0.45
H	4500 at 56 Days		580 to 640		5 – 8	0.38 to 0.42
P	4500 at 28 Days		660		4 – 8	0.44

**Class B** concrete is an air entrained concrete for general use. Class D, H or P concrete may be substituted for Class B concrete. Additional requirements are: The coarse aggregate shall have a nominal maximum size of 1½ inches or smaller.

### Sulfate Resistance.

The Contractor shall provide protection against sulfate attack on concrete structures by providing concrete manufactured according to the requirements of Table 0-4. The sulfate exposure for all concrete shall be Class 2 unless otherwise specified on the plans. A higher level of requirements may be used for a lower level of exposure.

If the Contractor provides test reports that show another class of exposure exists at a structure location, then CCD may accept a concrete mix for that location that meets the corresponding sulfate protection requirements.

Table 0-4: Concrete Sulfate Protection Requirements

Severity of Sulfate Exposure	Water-Soluble Sulfate (SO <sub>4</sub> ) in Dry Soil, Percent	Sulfate (SO <sub>4</sub> ) in Water, Ppm	Maximum Cementitious Material Ratio	Water to Cementitious Material Requirements
Class 0	0.00 to 0.10	0 to 150	0.45	Class 0
Class 1	0.11 to 0.20	151 to 1500	0.45	Class 1
Class 2	0.21 to 2.00	1501 to 10,000	0.45	Class 2
Class 3	2.01 or greater	10,001 or greater	0.40	Class 3

Cementitious material requirements are as follows:

- a) Class 0 requirements for sulfate resistance shall be one of the following:
  - a. ASTM C 150 Type I, II or V
  - b. ASTM C 595 Type IP, IP(MS) or IP(HS)
  - c. ASTM C 1157 Type GU, MS or HS
  - d. ASTM C 150 Type III cement if it is allowed, as in Class E concrete
- b) Class 1 requirements for sulfate resistance shall be one of the following:
  - a. ASTM C 150 Type II or V; Class C fly ash shall not be substituted for cement
  - b. ASTM C 595 Type IP(MS) or IP(HS); Class C fly ash shall not be substituted for cement.
  - c. ASTM C 1157 Type MS or HS; Class C fly ash shall not be substituted for cement.
  - d. When ASTM C 150 Type III cement is allowed, as in Class E concrete, it shall have no more than 8 percent C3 A. Class C fly ash shall not be substituted for cement
- c) Class 2 requirements for sulfate resistance shall be one of the following:

- a. ASTM C 150 Type V with a minimum of a 20 percent substitution of Class F fly ash by weight
  - b. ASTM C 150 Type II or III with a minimum of a 20 percent substitution of Class F fly ash by weight. The Type II or III cement shall have no more than 0.040 percent expansion at 14 days when tested according ASTM C 452
  - c. ASTM C 1157 Type HS; Class C fly ash shall not be substituted for cement.
  - d. ASTM C 1157 Type MS plus Class F fly ash where the blend has less than 0.05 percent expansion at 6 months or 0.10 percent expansion at 12 months when tested according to ASTM C 1012
  - e. A blend of portland cement meeting ASTM C 150 Type II or III with a minimum of 20 percent Class F fly ash by weight, where the blend has less than 0.05 percent expansion at 6 months or 0.10 percent expansion at 12 months when tested according to ASTM C 1012.
  - f. ASTM C 595 Type IP(HS); Class C fly ash shall not be substituted for cement.
- d) Class 3 requirements for sulfate resistance shall be one of the following:
- a. A blend of portland cement meeting ASTM C 150 Type II, III, or V with a minimum of a 20 percent substitution of Class F fly ash by weight, where the blend has less than 0.10 percent expansion at 18 months when tested according to ASTM C 1012.
  - b. ASTM C 1157 Type HS having less than 0.10 percent expansion at 18 months when tested according to ASTM C 1012. Class C fly ash shall not be substituted for cement
  - c. ASTM C 1157 Type MS or HS plus Class F fly ash where the blend has less than 0.10 percent expansion at 18 months when tested according to ASTM C 1012.
  - d. ASTM C 595 Type IP(HS) having less than 0.10 percent expansion at 18 months when tested according to ASTM C 1012. Class C fly ash shall not be substituted for cement.
  - e. When fly ash is used to enhance sulfate resistance, it shall be used in a proportion greater than or equal to the proportion tested in accordance to ASTM C1012, shall be the same source and it shall have a calcium oxide content no more than 2.0 percent greater than the fly ash tested according to ASTM 1012.

## Proportioning

The Contractor shall submit a Concrete Mix Design for each class of concrete being placed on the project. Concrete shall not be placed on the project before the Concrete Mix Design Report has been reviewed and approved by CCD. The Concrete Mix Design will be reviewed and approved following the procedures of CP 62. The Concrete Mix Design will not be approved when the laboratory trial mix data are the results from tests performed more than two years in the past or aggregate data are the results from tests performed more than two years in the past. The concrete mix design shall show the weights and sources of all ingredients including cement, pozzolan, aggregates, water, additives and the water to cementitious material ratio (w/cm). When determining the w/cm, the weight of cementitious material (cm) shall be the sum of the weights of the cement, fly ash and silica fume.

The laboratory trial mix data shall include results of the following:

- a) AASHTO T 119 (ASTM C 143) Slump of Hydraulic Cement Concrete.
- b) AASHTO T 121 (ASTM C 138) Weight per Cubic Foot, Yield, and Air Content (Gravimetric) of Concrete.
- c) AASHTO T 152 (ASTM C 231) Air Content of Freshly Mixed Concrete by the Pressure Method
- d) ASTM C 39 Compressive Strength of Cylindrical Concrete Specimens shall be performed with at least two specimens at 7 days and three specimens at 28 days. Three additional specimens tested at 56 days shall be required for Class H concrete.
- e) Class H concrete shall include a measurement of permeability by ASTM C 1202 Electrical Indication of Concrete's Ability to Resist Chloride Ion Penetration.
- f) Class H concrete shall include a measurement of cracking by AASHTO T334 Standard Practice for Estimating the Cracking Tendency of Concrete. The sample shall be cured at a temperature of 65 to 75 °F and relative humidity not exceeding 40 percent.
- g) Class P concrete shall include AASHTO T 97 (ASTM C 78) Flexural Strength of Concrete (Using Simple Beam with Third-Point Loading) performed with at least two specimens at seven days and four specimens at 28 days. The Contractor shall provide maturity meters and all necessary wires and connectors.

The Contractor shall be responsible for the placement and maintenance of the maturity meters and wires. Placement shall be as directed by CCD.

The maximum slump of the delivered concrete shall be the slump of the approved concrete mix design plus 1½ inch. The laboratory trial mix must produce an average compressive strength at least 115 percent of the required field compressive strength specified in Table A-5.

The laboratory trial mix shall have a relative yield of 0.99 to 1.02. If the produced concrete does not have a relative yield of 0.99 to 1.02 for two consecutive yield determinations, concrete production shall cease and the Contractor shall present a plan to correct the relative yield to CCD.

Aggregate data shall include the results of the following:

- a) AASHTO T 11 (ASTM C 117) Materials Finer Than 75 um (No. 200) Sieve in Mineral Aggregates by Washing.
- b) AASHTO T 19 (ASTM C 29) Unit Weight and Voids in Aggregate.
- c) AASHTO T 21 (ASTM C 40) Organic Impurities in Fine Aggregate for Concrete.
- d) AASHTO T 27 (ASTM C 136) Sieve Analysis of Fine and Coarse Aggregates.
- e) AASHTO T 84 (ASTM C 128) Specific Gravity and Absorption of Fine Aggregate.
- f) AASHTO T 85 (ASTM C 127) Specific Gravity and Absorption of Coarse Aggregate.
- g) AASHTO T 96 (ASTM C 131) Resistance to Degradation of Small-Size Coarse Aggregate by Abrasion and Impact in the Los Angeles Machine.
- h) AASHTO T 104 (ASTM C 88) Soundness of Aggregate by Use of Sodium Sulfate or Magnesium Sulfate.
- i) CP 37 Plastic Fines in Graded Aggregates and Soils by use of the Sand Equivalent Test
- j) ASTM C 535 Resistance to Degradation of Large-Size Coarse Aggregate by Abrasion and Impact in the Los Angeles Machine
- k) ASTM C1260 Determining the Potential Alkali Reactivity of Aggregates (Accelerated Mortar-Bar Method). When an aggregate source is known to be reactive, ASTM C1567 results may be submitted in lieu of ASTM C1260 results.

Any aggregate tested by ASTM C1260 with an expansion of 0.10 percent or more, or that is known to be reactive, shall not be used unless mitigative measures are included in the mix design.

Test results from ASTM C1293 Standard Test Method for Determination of Length Change of Concrete Due to Alkali-Silica Reaction may be substituted for ASTM C1260 test results. The ASTM C1293 test shall be run on an individual source of aggregate. The ASTM C1293 test shall not use fly ash or slag as part of the cementitious material content. Any aggregate source tested by ASTM C1293 with an expansion greater than or equal to 0.04 percent at one year shall not be used unless mitigative measures are included in the mix design.

Mitigative measures shall be tested using ASTM C1567 and exhibit an expansion less than 0.10 percent by one of the following methods:

- a) Combined Aggregates. The mix design sources of aggregates, cement and mitigative measures shall be tested. The proportions of aggregates, cement and mitigative measures shall be those used in the mix design.
- b) Individual Aggregates. Each source and size of individual aggregates shall be tested. The source of cement and mitigative measures shall be those used in the mix design. The highest level of mitigative measures for any individual aggregate shall be the minimum used in the mix design.

The Concrete Mix Design Report shall include Certified Test Reports showing that the cement, fly ash and silica fume meet the specification requirements and supporting this statement with actual test results. The certification for silica fume shall state the solids content if the silica fume admixture is furnished as slurry.

Approved fly ash may be substituted for ASTM C150 cement up to a maximum of 20 percent Class C or 30 percent Class F by weight of total cementitious material.

For all concrete mix designs with ASTM C595 or C1157 cements, the total pozzolan content shall not exceed 30 percent by weight of the cementitious material content.

When the Contractor's use of fly ash results in any delay, necessary changes in admixture quantities or source, or unsatisfactory work, the cost of such delays, changes, or corrective actions shall be borne by the Contractor.

The Contractor shall submit a new Concrete Mix Design Report meeting the above requirements when a change occurs in the source, type, or proportions of cement, fly ash, silica fume or aggregate. When a

change occurs in the source of approved admixtures, the Contractor shall submit a letter stamped by the Concrete Mix Design Engineer approving the changes to the existing mix design. The change will be approved by CCD prior to use.

The use of approved accelerating, retarding or hydration stabilizing admixtures to existing mix designs will be permitted at the discretion of CCD when documentation includes the following:

- a) Manufacturer's recommended dosage of the admixture
- b) A letter stamped by the Concrete Mix Design Engineer approving the changes to the existing mix design.

Unless otherwise permitted by CCD, the product of only one type of hydraulic cement from one source of any one brand shall be used in a concrete mix design.

Review and approval of the Concrete Mix Design by CCD does not constitute acceptance of the concrete. Acceptance will be based solely on the test results of concrete placed on the project.

## Batching

Measuring and batching of materials shall be done at a batching plant in accordance with AASHTO M 157.

The Contractor shall furnish a batch ticket (delivery ticket) with each load for all classes of concrete. Concrete delivered without a batch ticket containing complete information as specified shall be rejected. The Contractor shall collect and complete the batch ticket at the placement site and deliver all batch tickets to CCD on a daily basis. CCD shall have access to the batch tickets at any time during the placement. The following information shall be provided on each batch ticket:

- a) Supplier's name and date
- b) Truck number
- c) Project number and location
- d) Concrete class designation and item number
- e) Cubic yards batched
- f) Time batched
- g) Mix design number
- h) Type, brand, and amount of each admixture
- i) Type, brand, and amount of cement and fly ash
- j) Weights of fine and coarse aggregates
- k) Moisture of fine and coarse aggregate
- l) Gallons (Pounds) of batch water (including ice)
- m) Gallons of water added by truck operator plus quantity of concrete in the truck each time water is added
- n) Number of revolutions of drum at mixing speed (for truck mixed concrete)
- o) Discharge time
- p) Location of batch in placement
- q) Water to cementitious material ratio (required for deck concrete only)

The drum on each truck mixer shall be reversed prior to charging to eliminate any wash water remaining in the mixer.

- a) *Portland Cement and Fly Ash.* Either sacked or bulk cement may be used. No fraction of a sack of cement shall be used in a batch of concrete unless the cement is weighed.

All bulk cement shall be weighed on an approved weighing device. The bulk cement weighing hopper shall be sealed and vented to preclude dusting during operation. The discharge chute shall be so arranged that cement will not lodge in it or leak from it.

Separate storage and handling equipment shall be provided for the fly ash. The fly ash may be weighed in the cement hopper and discharged with the cement.

- b) *Water.* Unless water is to be weighed, the water-measuring equipment shall include an auxiliary tank from which the measuring tank shall be filled. The measuring tank shall be equipped with an outside tap and valve to provide for checking the calibration unless other means are provided for readily and accurately determining the amount of water in the tank. The volume of the auxiliary



tank shall be at least equal to that of the measuring tank. In lieu of the volume method specified above, the Contractor will be permitted to use a water metering device that is accurate within the prescribed limits.

- c) *Aggregates.* Aggregates from different sources and of different gradings shall not be stockpiled together.

Aggregate shall be handled from stockpiles or other sources to the batching plant in such manner as to secure a uniform grading of the material. Aggregates that have become segregated, or mixed with earth or foreign material, shall not be used. All aggregates produced or handled by hydraulic methods, and washed aggregates, shall be stockpiled or binned for draining at least 12 hours before being batched. Rail shipment requiring more than 12 hours will be accepted as adequate binning only if the car bodies permit free drainage. In case the aggregates contain high or non-uniform moisture content, storage or stockpile period in excess of 12 hours may be required.

- d) *Bins and Scales.* The batching plant may include bins, weighing hoppers, and scales for the fine aggregate and for each size of coarse aggregate. If cement is used in bulk, a bin, hopper, and scale for cement shall be included. A single weighing hopper with an accumulative scale will be permitted, provided a separate scale is used for weighing cement.

## Mixing

Concrete may be mixed in stationary mixers, in a central-mix plant, in truck mixers, or in self-contained mobile mixers. Mixing time shall be measured from the time all materials, except water, are in the drum.

Silica fume, when specified, shall be added to the mix during initial batching.

- a) *Mixing General.* The concrete shall be deposited in place within 90 minutes after batching when concrete is delivered in truck mixers or agitating trucks, and within 60 minutes when delivered in non-agitating trucks.
- a. The 90 minute time limit for mixer or agitating trucks may be extended to 120 minutes if:
    - i. No water is added after 90 minutes.
    - ii. The concrete temperature prior to placement is less than 90 °F
  - b. The 90 minute time limit for mixer or agitating trucks may be extended to 180 minutes if:
    - i. No water is added after 90 minutes.
    - ii. The concrete temperature prior to placement is less than 90 °F.
    - iii. The approved concrete mix contains a water reducing and retarding admixture which conforms to AASHTO M 194, Type D.
- b) *Stationary Mixing.* When mixed in a central mixing plant, the mixing time shall be between 50 and 90 seconds. Four seconds shall be added to the specified mixing time if timing starts the instant the skip reaches its maximum raised position. Mixing time ends when the discharge chute opens. Transfer time in multiple drum mixers is included in mixing time. The contents of an individual mixer drum shall be removed before a succeeding batch is emptied therein.

The volume of concrete mixed per batch may exceed the mixer's nominal capacity, as shown on the manufacturer's standard rating plate on the mixer, up to 10 per cent provided concrete test data for strength, segregation, and uniform consistency are satisfactory, and provided spillage of concrete does not occur.

The batch shall be so charged into the drum that a portion of the mixing water shall enter in advance of the cement and aggregates. The flow of water shall be uniform and all water shall be in the drum by the end of the first 15 seconds of the mixing period. The throat of the drum shall be kept free of such accumulations as may restrict the free flow of materials into the drum.

The timing device on stationary mixers shall be equipped with a bell or other suitable warning device adjusted to give a clearly audible signal each time the lock is released. In case of failure of the timing device, the Contractor will be permitted to operate while it is being repaired, provided the Contractor furnishes an approved timepiece equipped with minute and second hands. If the

timing device is not placed in good working order within 24 hours, further use of the mixer will be prohibited until repairs are made.

- c) *Truck Mixing.* Truck mixed concrete shall conform with one of the following:
- a. Concrete mixed entirely in a truck mixer equipped with a mechanical counter shall be partially mixed at the plant or in transit for not less than 20 revolutions of the drum at mixing speed. The revolutions of the drum at charging speed shall not be counted as mixing revolutions. The concrete shall be mixed between 50 and 100 revolutions of the mixer drum at mixing speed at the delivery site before discharge of the concrete.
  - b. Concrete partially mixed in a stationary central mixing plant with mixing brought to completion in a truck mixer (known as shrink mixing) shall be mixed for a minimum of 30 seconds in the stationary mixer. Mixing shall be completed in the truck mixer for at least 20 but not more than 100 revolutions of the mixer drum at mixing speed at the delivery site before discharge of the concrete.
  - c. Concrete mixed entirely in a stationary mixer and delivered to the job in a truck mixer shall be remixed for a minimum of 20 revolutions of the mixing drum at mixing speed at the job site prior to discharge.

When water is added at the delivery site to control the consistency of the concrete, the concrete shall be mixed for at least 20 revolutions of the mixer drum at mixing speed for each addition of water before discharge. These revolutions are in addition to the minimum revolutions required for mixing at the delivery site. Water from all sources shall be documented by the ready mix producer on the delivery slip for each load of concrete.

The Contractor shall provide a Concrete Truck Mixer Certification. This certification shall show the various pick-up and throw-over configurations and wear marks so that the wear on the blades can be checked. Blades shall be replaced when any part or section is worn 1 inch or more below the original height of the manufacturer's design. A copy of the manufacturer's design, showing the dimensions and arrangement of blades, shall be available to CCD at all times.

The Contractor shall furnish a water-measuring device in good working condition, mounted on each transit mix truck, for measuring the water added to the mix after the truck has left the charging plant. Each measuring device shall be equipped with an easy-to-read gauge. Water shall be measured to the accuracy prescribed in AASHTO M 157.

- d) *Self Contained Mobile Mixer.* Proportioning and mixing equipment shall be of the self-contained, mobile, continuous mixing type subject to the following:
- a. The mixer shall be self-propelled and be capable of carrying sufficient unmixed dry, bulk cement, fine aggregate, coarse aggregate, admixtures and water to produce on the site not less than 6 cubic yards of concrete. The mixer shall have one bin for each size aggregate.
  - b. The mixer shall be capable of positive measurement of cement being introduced into the mix. A recording meter visible at all times and equipped with a ticket printout shall indicate the quantity of total concrete mix.
  - c. The mixer shall provide positive control of the flow of water into the mixing chamber. Water flow shall be indicated by flow meter and be readily adjustable to provide for minor variations in the aggregate moisture.
  - d. The mixer shall be capable of being calibrated to automatically proportion and blend all components of indicated composition on a continuous or intermittent basis as required by the finishing operation, and shall discharge mixed material through a conventional chute directly in front of the finishing machine.
  - e. The Contractor shall perform calibration tests according to the equipment manufacturer's recommendations at the beginning of each project, and when there is a change in the mix design proportions or source of materials. CCD may require a calibration test or yield check whenever a change in the characteristics of the mixture is observed. The tolerances in proportioning the various ingredients shall be according to subsection 6.8 of AASHTO M 241.

## Air Content Adjustment

When a batch of concrete delivered to the project does not conform to the minimum specified air content, an air entraining admixture conforming to AASHTO M 154 may be added. After the admixture is added, the concrete shall be re-mixed for a minimum of 20 revolutions of the mixer drum at mixing speed. The concrete shall then be re-tested by QC.

## Acceptance and Pay Factors

These provisions apply to all concrete. The Contractor shall sample concrete items for both QC and QA in accordance with CP 61. CCD will witness the sampling and take possession of the QA samples at a mutually agreed upon location.

- a) *Air Content.* The first three batches at the beginning of production shall be tested by QC and QA for air content. When air content is below the specified limit, it may be adjusted in accordance with Section 6.4 – Air Content Adjustment. Successive batches shall be tested by QC and witnessed by CCD until three consecutive batches are within specified limits. After the first three batches, the City will follow the random minimum testing schedule. Air content shall not be adjusted after a QA test.
- b) *Slump.* Slump acceptance, but not rejection, may be visually determined by CCD. During the placement of the concrete, when a batch exceeds the maximum slump specified, the following procedure shall be used to analyze the acceptability of the concrete.
  - a. A batch that exceeds the maximum slump specified by more than 1 inch will be rejected. Portions of loads incorporated into structures prior to determining test results which indicate rejection as the correct course of action shall be subject to acceptance at reduced price, no payment, or removal as determined by CCD.
  - b. A batch that exceeds the maximum slump specified by 1 inch or less may be incorporated into the project at a reduced price, calculated as follows: The first batch that exceeds the maximum slump specified by  $\frac{1}{2}$  inch or less will be accepted at full price. The first batch that exceeds the maximum slump specified by more than  $\frac{1}{2}$  inch and up to 1 inch, which the Contractor elects to place, will be accepted at a reduced price. The second and third successive batches of a series that exceed the maximum slump specified by 1 inch or less, which the Contractor elects to place, will be accepted at a reduced price. The fourth and all other successive batches of a series that exceed the maximum slump specified shall be rejected. The rejected batch count will stop with a batch that has less than the maximum slump, and will resume at one with the next batch that exceeds the maximum slump.
- c) *Strength (When Specified).* The concrete will be considered acceptable when the running average of three consecutive strength tests is equal to or greater than the specified strength and no single test falls below the specified strength by more than 500 psi. A test is defined as the average strength of three test cylinders cast in plastic molds from a single sample of concrete and cured under standard laboratory conditions prior to testing. If the compressive strength of any one test cylinder differs from the average by more than 10 percent that compressive strength will be deleted and the average strength will be determined using the compressive strength of the remaining two test cylinders.

For concrete having specified strength of 4500 psi or greater, when the compressive strength test is below the specified strength by more than 500 psi but not more than 1000 psi, the concrete represented will be evaluated by CCD for removal, corrective action, or acceptance at a reduced price. All costs of the evaluation shall be at the Contractor's expense. When the compressive strength test is below the specified strength by more than 1000 psi, the concrete represented will be rejected.

CCD may use cores to determine acceptance or rejection of a part of the structure instead of acceptance cylinders. CCD will notify the Contractor within 10 working days after concrete placement that the City may core the structure. The location of the coring will be directed by CCD.

Coring and testing will be performed at the expense of the City regardless of the result. Cores will be taken and tested in accordance with AASHTO T24 between 28 days and 45 days after concrete placement. Cores will be a minimum of 4 inches in diameter, unless otherwise approved by CCD. A minimum of three cores in a two square foot area will be obtained for locations of the structure that are suspect. If the compressive strength of any one core differs from the average by more than 10 percent that compressive strength will be deleted and the average strength will be determined using the compressive strength of the remaining two cores. If the compressive strength of more than one core differs from the average by more than 10 percent the average strength will be determined using all three compressive strengths of the cores. If the average core compressive strength is greater than or equal to 85 percent of the specified 28-day compressive strength, the concrete represented by the cores will be accepted. If the concrete represented by the cores is accepted, all costs associated with the repair of the core holes, including preparation and submittal of the repair method, will be measured and paid for separately.

After the City performs additional core testing as described above, the Contractor may make one request that the structure be cored and reevaluated by the City within 45 days after concrete placement.

Coring and testing costs will be at the expense of the Contractor regardless of the result. Cores shall be taken at the same area of the structure as those obtained by CCD. CCD will approve the location of the cores prior to the Contractor coring the structure. All costs associated with the repair of these core holes, including preparation and submittal of the repair method, will not be measured and paid for separately, but shall be included in the work. If the concrete in the structure is found to be sufficient resulting time delays will be considered excusable.

If the concrete in the structure is still found to be deficient, resulting time delays will be considered non-excusable for this evaluation.

The Contractor shall submit a proposed repair method for the core holes for approval prior to coring. The method shall use an approved non-shrink concrete patching material with a minimum compressive strength of 4500 psi. The Contractor shall submit the manufacturer's recommendations along with the repair method. CCD will review and approve the proposed methodology prior to patching. Class HT concrete overlays shall not be opened to traffic, including construction traffic, for at least 14 days after placement. At CCD's discretion, the overlay may be opened to construction traffic sooner than 14 days but not until after the curing period has elapsed and the average strength of two field cured cylinders has reached 4500 psi. The field cured cylinders shall be made in accordance with AASHTO T 23 Making and Curing Concrete Test Specimens in the Field.

Unless otherwise stated in the plans or specifications, tolerances for concrete construction and materials shall be in accordance with ACI 117.

END OF SECTION

## B.5 Reinforcing Steel

### Description

This work consists of furnishing and placing reinforcing steel in accordance with these specifications and in conformity with the plans.

### Reinforcing Steel

Reinforcing steel shall conform to the requirements of the following specifications:

Deformed and Plain Billet-Steel Bars for Concrete Reinforcement	ASTM A 615
Axle-steel Deformed and Plain Bars for Concrete Reinforcement	ASTM A 996
Low-Alloy Steel Deformed Bars for Concrete Reinforcement [to be Welded]	ASTM A 706
Fabricated Deformed Steel Bar Mats for Concrete Reinforcement	ASTM A 184

Unless otherwise designated, bars conforming to ASTM A 615 & ASTM A 996 shall be furnished in Grade 60 for # 5 bars and larger and Grade 40 or 60 for bars smaller than # 5.

In ASTM A 184, bar material conforming to ASTM A 616 will not be permitted.

### Bar List

Two copies of a list of all reinforcing steel and bending diagrams shall be furnished to CCD at the site of the work at least one week before the placing of reinforcing steel is begun. Such lists will not be reviewed for accuracy. The Contractor shall be responsible for the accuracy of the lists and for furnishing and placing all reinforcing steel in accordance with the details shown on the plans.

Bar lists and bending diagrams which are included on the plans, do not have to be furnished by the Contractor. When bar lists and bending diagrams are included on the plans, they are intended for estimating approximate quantities. The Contractor shall verify the quantity, size and shape of the bar reinforcement against those shown on the plans and make all necessary corrections before ordering.

### Protection of Materials

Reinforcing steel shall be protected at all times from damage. When placed in the work, the reinforcing steel shall be free from dirt, loose mill scale, paint, oil, loose rust, or other foreign substance.

### Bending

Unless otherwise permitted, all reinforcing bars shall be bent cold. Bars partially embedded in concrete shall not be field bent except as shown on plans or permitted. Bars shall not be bent or straightened in a manner that will injure the material. Should CCD approve the application of heat for field bending reinforcing bars, precautions shall be taken to assure that the physical properties of the steel will not be materially altered.

### Placing and Fastening

The minimum spacing center to center of parallel bars shall be  $2\frac{1}{2}$  times the diameter of the bar. However, the clear distance between the bars shall not be less than  $1\frac{1}{2}$  times the maximum size of the coarse aggregate or  $1\frac{1}{2}$  inches, whichever is greater.

Bundle bars shall be tied together at not more than 6-foot centers.

All reinforcement shall have a clear coverage of 2 inches, except as shown on the plans. Clear coverage shall be measured from the surface of the concrete to the outside of the reinforcement.

Reinforcement used in post-tensioned concrete shall be adjusted or relocated during the installation of prestressing ducts or tendons, as required, to provide location and planned clearances to the prestressing tendons, anchorages, jacks and equipment as approved by CCD.

All reinforcement shall be tied at all intersections except where spacing is less than 1 foot in each direction, in which case alternate intersections shall be tied.

The placing, fastening, splicing and supporting of reinforcing steel reinforcement shall be in accordance with the plans and the latest edition of “CRSI Recommended Practice for Placing Reinforcing Bars.” In case of discrepancy between the plans and the CRSI publication stated above, the plans shall govern. Automated tie wire devices may be used. The total cross-sectional area of the automated tie wire wrap shall roughly equal the total cross-sectional area of a manually installed tie wire wrap.

END OF SECTION

## SMALL CELL INFRASTRUCTURE IN DENVER



### C Small Cell Infrastructure in Denver

The following section describe what a small cell is, why they are being installed in Denver, and who to contact for additional information.

Refer to Appendix C for more information about why small cells are being installed in Denver.

# Small Cell Infrastructure in Denver



The City and County of Denver is receiving growing numbers of requests from wireless providers and wireless infrastructure companies to construct small cell facilities in the public right of way.

---

## What are Small Cell facilities?

- Small Cell facilities are low-powered antennas that provide cellular and data coverage to smaller geographic areas, supplementing the larger cellular network.
- Small Cell equipment is proposed to be located on poles, wires, or buildings.
- Small Cell equipment is allowed in the public right of way per Federal and State Law just like other utilities.
- Small Cell equipment will initially meet current 4G (LTE) voice and data demands, but we understand it may be modified with future 5G higher speed equipment as technology changes.

## What is the role of Denver Public Works related to Small Cell infrastructure?

- Denver Public Works reviews applications for Small Cell equipment in the public right of way.
- Requests for Small Cell equipment on new freestanding poles are processed as Encroachment Permits. State law requires the City to process applications in batches (currently 10 poles or less per application), and in 90 days or less.
- Denver Public Works is working with each proposing carrier to standardize the physical and aesthetic appearance of equipment as much as possible.
- Denver Public Works is having success requesting that applicants limit the height of new freestanding poles to less than 35 feet, similar to existing street lighting in the public right of way.
- Denver Public Works is encouraging co-location of new equipment onto existing poles and infrastructure in the public right of way wherever possible.





# Small Cell Infrastructure is coming to Denver

Here's the current state of Small Cell technology, as we understand it from the wireless carrier industry.

## 1. Why are we seeing a surge in interest to install wireless infrastructure?

Researchers say mobile data traffic in North America has grown significantly, and is projected to continue increasing at a rapid rate with the proliferation of mobile devices. In our City there has been a surge in population and economic growth, and wireless carrier companies are indicating that existing infrastructure is becoming congested and cannot continue to meet the demands of their customers.

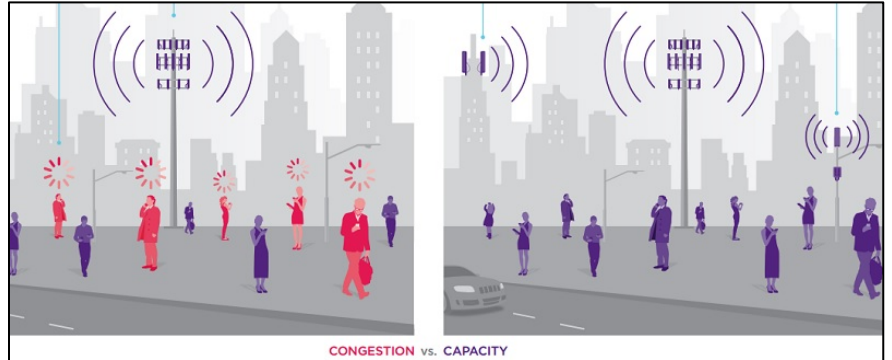

Source: Crown Castle

## 2. What type of infrastructure is proposed?

Wireless carrier companies have indicated that until recently, wireless phone service in general has been managed using large antennas mounted on towers located on both public and private property. Those antennas serve relatively large areas, or "cells" up to several miles away. Carriers have explained to the City that existing cell sites are already becoming congested and that installing more cell towers covering large areas will not keep up with projected demand for high speed wireless data that is growing rapidly.



Typical large cellular antenna.

Credit: Joe Ravi via Wikimedia Commons

To meet demands for wireless data, carriers have begun using new lower-powered antenna technology to "offload" data traffic from the larger cell towers. Each of these smaller antennas serves a much smaller area (1-2 blocks) but with much higher data volumes. This type of wireless infrastructure is referred to as "Small Cell."

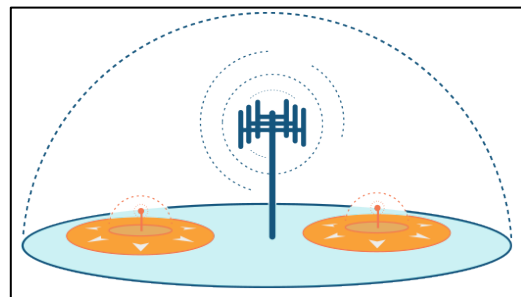

Data is transferred from Small Cells to large antenna

Source: Qualcomm Technology

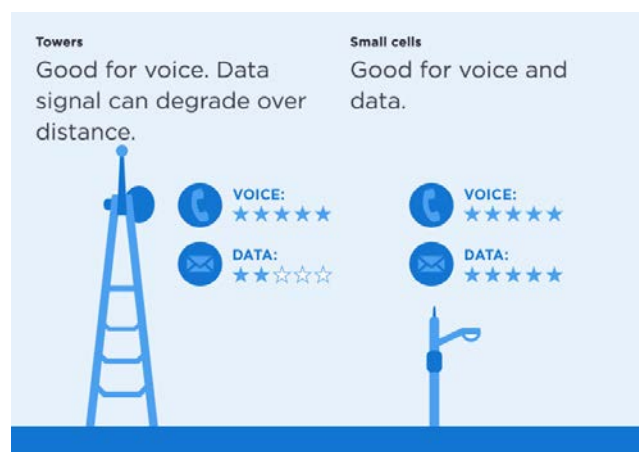

Source: Crown Castle

Small Cell antenna equipment is typically the size of a suitcase and must be under 20 cubic feet in total volume according to State law. The types of equipment and method of deployment being proposed in Denver will vary widely and depend upon the network needs and technology requirements of the various wireless carriers. Typical antenna locations are expected to be:

- Mounted onto existing utility or street lighting poles.
- Placed onto new freestanding poles erected in the public right of way.
- Strung on wires between existing poles.
- Mounted onto existing buildings on public and private property.

There are an estimated 60,000 plus Small Cell units already operating nationwide. Requests for Small Cell antenna installations in the City of Denver are expected to rise in the coming months as wireless companies work to meet the increasing wireless data demands of their customers. We understand hundreds, if not thousands, of additional Small Cell antennas may be proposed in Denver by cellular carrier companies.

It appears that most new infrastructure being proposed today is servicing current 4G (“4<sup>th</sup> Generation”) cellular and data needs, also known as “LTE”. However, wireless carriers are already preparing plans for imminent 5G (“5<sup>th</sup> Generation”) wireless networks, expected to service even higher speed data from densely placed antennas.

### 3. Types of Applicants

Denver has learned that the companies that intend to build Small Cell infrastructure follow different business models. Some companies will construct their own infrastructure to service wireless demand from their own customers (AT&T and Verizon Wireless, for example). Other companies will construct wireless infrastructure and then lease or sell service to wireless providers that do not wish to construct and own their own equipment (Crown Castle for T-Mobile, and Mobilitie for Sprint, for example).

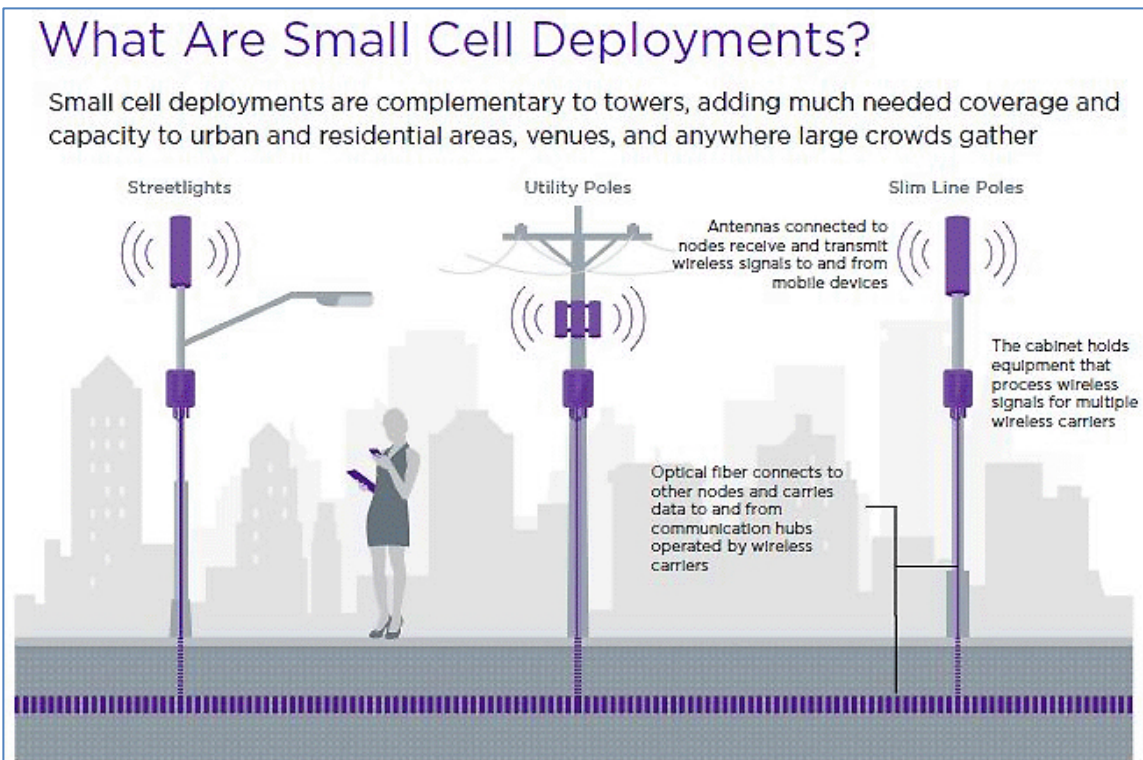
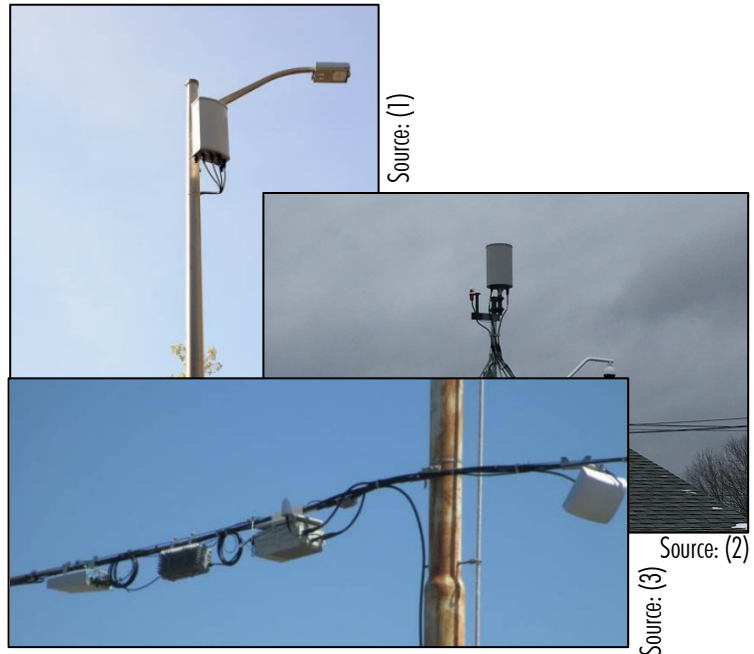

Source: Crown Castle

Photo Sources: (1) scientists4wiredtech.com; (2) steelintheair.com; (3) wade4wireless.com

## 4. Federal and State Law on Small Cell Infrastructure

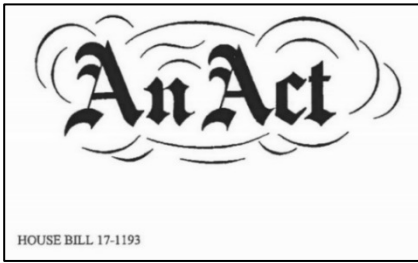

Wireless infrastructure is subject to the parameters of Federal Communications Commission (FCC) and State law. In addition to FCC requirements surrounding wireless radio placement and transmissions, the State of Colorado recently approved a new law in March of 2017 that establishes that wireless providers have the legal right to locate Small Cell equipment in the public rights of way of Colorado.

The new State law is specific that municipalities may not entirely deny or discriminate against Small Cell infrastructure, treating the equipment in the same way as other permitted users of the right of way. However, Denver still maintains the authority to

regulate new Small Cell equipment based on public health, safety, and welfare, and deny or require change to proposals that conflict with other uses of the public right of way or are otherwise unlawful.

Immediately following the passage of the State House Bill, the City experienced interest from multiple companies (see last page of this handout) and has received numerous applications for Small Cell equipment in the public right of way.

## 5. Why can't Small Cell equipment just be placed on current poles?



Of note, the City and County of Denver does not own or maintain most existing street lighting, utility, or traffic signal poles in the public right of way. The majority of these current poles are owned and maintained by Xcel Energy or other utility companies.

For years, Xcel and other utility companies have allowed the mounting of cellular equipment onto utility poles, and there are many existing examples throughout Denver. These locations are preferred for wireless networks as they are already standing, are of adequate height for antennas, and have electrical power nearby. However, space on utility poles is scarce, and becoming increasingly eliminated as poles are removed when unsightly overhead lines are relocated underground.

Just recently, Xcel Energy announced its intention to allow companies to attach (or "co-locate") Small Cell equipment onto existing street light poles in Denver. There are over 52,000 such poles throughout the City; however, it is unknown how many could possibly support additional equipment or be replaced with a pole/ light combination. The City understands that it each company must reach final agreement with Xcel Energy for co-locating, then work with Xcel to review and approve individual pole locations. Some street light locations that are not capable of accepting new equipment may be removed and replaced with a combination street light/ antenna pole.



Xcel Energy also owns and maintains most of the traffic signal poles in Denver (typically located at street intersections). The City of Denver has an exclusive agreement with Xcel Energy to locate signal, emergency response, and other municipal equipment (cameras, etc.) on traffic signal poles. The City is carefully evaluating whether it will be possible to allow additional wireless infrastructure on these poles without conflicting with current traffic or safety equipment.

## 6. Why can't cellular infrastructure be located on private property?

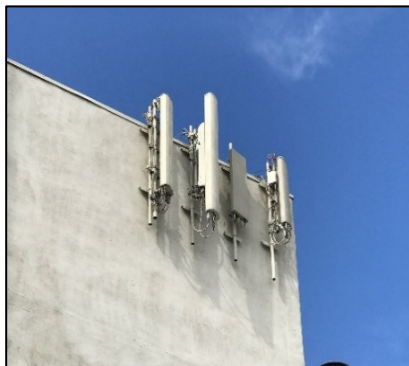

A quick glance around most parts of Denver will reveal many cellular antennas already located on private property. However, because of the complexities and length of time to create agreements with individual property owners, many companies have disclosed to the City that it is not feasible to deploy Small Cell equipment in this manner and still meet current data demands.

If and when a company identifies a good location for mounting Small Cell equipment on private property, it will be regulated by the City's Community Planning and Development Division using requirements of the current Denver [Zoning Code](#). The Zoning Code includes parameters for height, size, placement, etc. on private property to preserve the intent and character of the zoning district. Zoning Code requirements do not apply in public right of way.

## 7. Why can't cellular infrastructure be combined onto one pole?

For now, the City understands that the siting of Small Cell antennas is dictated by the wireless provider and its customer's needs, terrain, and radio frequency modeling results. Each wireless provider has different objectives and may not need the same locations. Each carrier, who owns rights to a spectrum of operating frequency, states that some separation with competing antennas is necessary to avoid signal interference.

With that said, the City understands that Small Cell technology is evolving rapidly towards the ability to share antennas or even poles between multiple carriers. The City is exploring all options and is encouraging pilot programs that demonstrate how the equipment for multiple carriers can be combined into a single pole, with the long-term goal of minimizing the amount of new infrastructure placed in the public right of way.

## 8. How is the City handling Small Cell infrastructure proposed in the public right of way?

The City is currently reviewing all new pole applications in conjunction with Federal and State law, as well as Denver Rules and Ordinances. Denver Public Works is the responsible entity for permitting any infrastructure, object, or construction in the public right of way of Denver.

Public Works currently performs careful consultation with top executive and program management staff from each wireless provider about proposed infrastructure programs before the provider is allowed to submit any applications for approval. This ensures that each provider approaches the City in a consistent manner, and that the City's current policies and permitting procedures are well known at the outset.

Per State law, the City must allow each company to propose their infrastructure in the public right of way. Additionally, the City must offer permitting procedures that can process "bulk" Small Cell programs in batches, in 90 days or less, rather than requiring individual permits for each pole or antenna.

In response to these requirements, Public Works has established a plan review and permitting program that combines existing Utility Plan Review and Encroachment Permitting into one contiguous process. Each applicant may submit batches of 10 or fewer unique poles or pieces of ground-mounted equipment per application. Each application will result in a revocable Encroachment Permit.



This batch permitting system ensures that each Small Cell application follows the same procedures and standards as any other user of the public right of way, while minimizing City processing and administration labor.

Each Encroachment Permit requires a complete and public-facing plan review process. The City Public Works Department logs each application for review by internal and external stakeholders (such as utility companies, etc.), special Districts, and known neighborhood groups using an electronic plan review website. The City has created procedures that will also ensure the applicant has notified adjacent property owners at each proposed pole location during this process.

Any comments received from the plan review process are accepted and must be addressed by the applicant. Comments that are deemed to have technical merit (identifying unlawful or conflicting proposed infrastructure) are required to be fully resolved by the applicant.

If an Encroachment Permit is issued, the associated batch of new poles is approved to proceed to Right of Way Construction Permitting.

Of note, the very first Encroachment Permit for ground-mounted Small Cell equipment by any Company requires approval by City Council. Additionally, each pole or piece of ground-mounted equipment approved by an Encroachment Permit requires a \$200 annual fee, and every Permit is revocable by the City under specified circumstances.

## 9. Can the City limit or standardize Small Cell infrastructure?

As mentioned above, the City is currently exploring its policies and ordinances for Small Cell infrastructure within the parameters of Federal and State law. Under current law, it is not clear how the City can restrict height, design, or location (unless conflicting) of Small Cell infrastructure. However, as the City as a whole considers new policies and rulemaking, the City Public Works Department is having success in coordinating expectations and recommendations through enhanced communication efforts at the outset of each company's program. So far each applicant has been receptive to:







- Considering standardizing pole design elements, color, location, etc. to meet intent and character of existing infrastructure in the public right of way.
- Limiting pole heights to match existing street lighting and other poles in the public right of way.
- Generally avoiding placing poles adjacent to parks and historical places.
- Encouraging pole and equipment designs that enclose as much equipment as possible to minimize visual impact.
- Co-locating equipment onto existing infrastructure wherever feasible.
- Installing consistent infrastructure that does not discriminate based on neighborhood type, demographic, or character.
- Exploring new concepts in combining equipment from multiple companies into single poles.

Public Works has placed top priority in coordinating design elements for proposed Small Cell infrastructure, and how companies should maximize aesthetics while minimizing congestion of the public right of way. Below are several examples of new Small Cell equipment recently constructed in Denver.



## 10. Who can I contact?

The City and County of Denver strongly encourages direct communication with the specific wireless provider or company who is installing specific equipment. City and County of Denver staff is also available to discuss processing and policy related questions. The following list of contacts that have approached the City so far is provided for your convenience:

NAME	EMAIL ADDRESS	AFFILIATION
Denver Public Works Regulatory: Jon Reynolds	<a href="mailto:denver.pwera@denvergov.org">denver.pwera@denvergov.org</a>	
Denver Public Works Communications & Marketing:	<a href="mailto:pw.comms@denvergov.org">pw.comms@denvergov.org</a>	
Verizon Wireless Debbie Essert	<a href="mailto:Debbie.ESSERT@verizonwireless.com">Debbie.ESSERT@verizonwireless.com</a>	
Mobilitie (currently servicing Sprint): Jennifer Johnson	<a href="mailto:Jennifer.Johnson@mobilitie.com">Jennifer.Johnson@mobilitie.com</a>	
Crown Castle (currently servicing T-Mobile): Scott Harry	<a href="mailto:Scott.Harry@crowncastle.com">Scott.Harry@crowncastle.com</a>	
Zayo Group: Alec Geist	<a href="mailto:Alec.Geist@zayo.com">Alec.Geist@zayo.com</a>	
AT&T Wireless: Jennifer Price	<a href="mailto:jp210a@att.com">jp210a@att.com</a>	
Xcel Energy Facility Attachments: Tom Breuckman	<a href="mailto:Tom.Breuckman@xcelenergy.com">Tom.Breuckman@xcelenergy.com</a>	