

HISTORIC DENVER NEWS

EST. 1970 * VOLUME 45 * NUMBER 2 * SPRING 2016

KRISANA PARK MOVING FORWARD WITH CONSERVATION OVERLAY

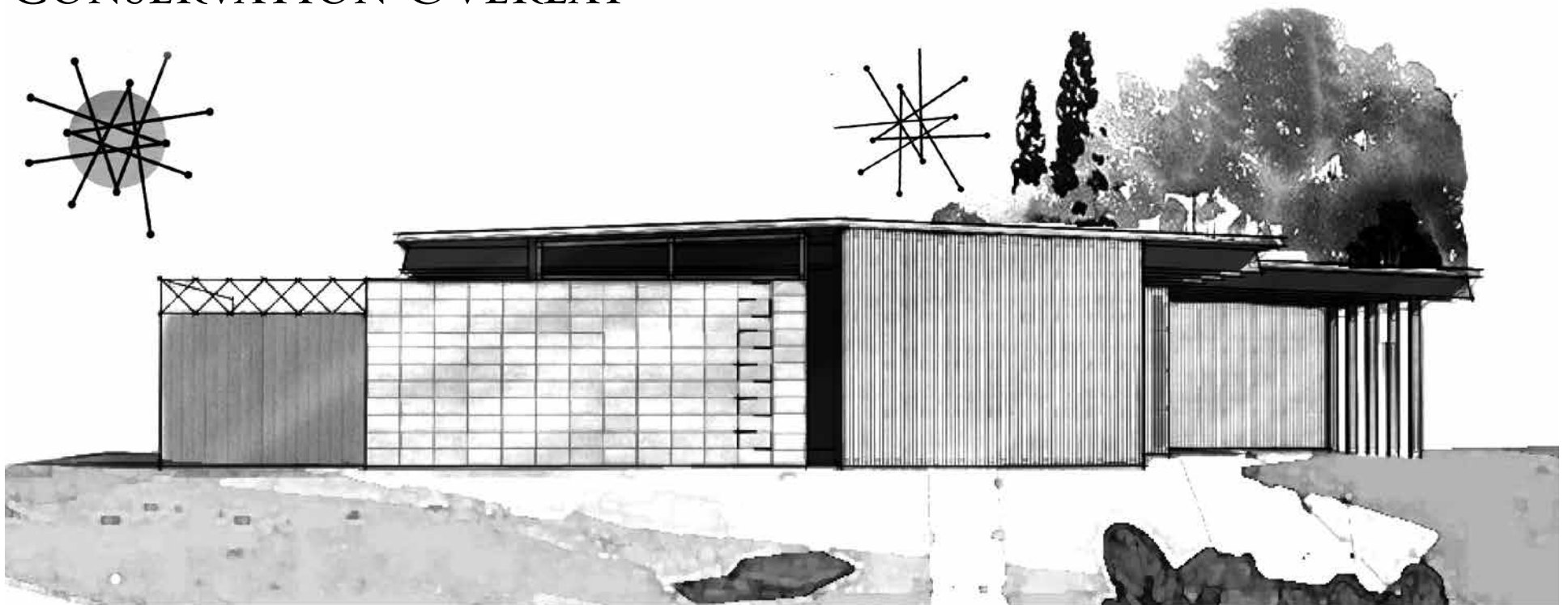

Krisana Park Pattern Book ideas for a midcentury modern neighborhood, denver, colorado



COLLEGE OF ARCHITECTURE AND PLANNING
Center of Preservation Research
UNIVERSITY OF COLORADO DENVER



National Trust for
Historic Preservation

BY BECCA DIERSCHOW, PRESERVATION AND RESEARCH COORDINATOR

When Denver's zoning code was updated in 2010, the city moved from the traditional, single use (or Euclidian) zoning code, which establishes zone districts restricted by use. Instead, the city opted for a form-based zoning code, a model which is at the forefront of urban planning policy. Proponents of form-based zoning maintain that these codes are a superior zoning model because they "identify geographic areas or groups of areas and create 'zones' for each that are based not on uses, but on desired community character, intensity of land use, and built form."

Indeed, as we've seen in Denver, many of our most popular neighborhoods such as Highland, Lower Downtown, and Uptown, could not have been built under our previous use-based zoning code, because they mix residential, commercial, and communal uses. The new form-based code tries to foster mixed use communities by dictating building form (height, setback, density) while including mixed uses as an integral part of the code.

As with any large scale document, there are a number of tweaks to be made along the way. After all, the document does cover 153 square miles of land. Now that neighbors have lived with the code for 6 years the city is seeing a number of rezoning applications as people work to find the most appropriate forms for their neighborhoods.

One of the most promising tools included in the new zoning code is the conservation overlay. A zoning overlay can come in many different forms, but essentially it provides a refinement of the base zoning to more accurately reflect the desired pattern of a neighborhood. A conservation overlay identifies key features of an existing neighborhood, and, through specific zoning requirements, shapes future development to be more compatible with those existing conditions. To date, there are four conservation overlays in Denver, covering parts of Curtis Park, Hilltop and Highland. Because a conservation overlay is designed to shape zoning for a particular context, these overlays are relatively small and cover only residential properties in

these neighborhoods. Conservation overlays require the support of at least 51% of included landowners.

Conservation overlays can be simple, only addressing one characteristic of a neighborhood—such as minimum lot size, as in Hilltop. Conservation overlays can also be more complex, as in Highland, where they cover several characteristics such as roof height and pitch and side set back requirements. Overlays don't necessarily have to be more restrictive, either. In Curtis Park, the conservation overlay is more permissive than the underlying zoning, allowing larger garages or accessory dwelling units than allowed in the underlying urban residential zone district because this reflects the historical pattern of development in the neighborhood.

One proposed conservation overlay currently moving forward through the city process is in the Krisana Park neighborhood. Historic Denver has been working with Krisana Park in various capacities over the last few years, and we are excited to see them move forward with this overlay proposal.

Krisana Park is a four block enclave of Midcentury Modern homes in Virginia Village, designed in a California Contemporary, Eichler-inspired style. Built in 1954, developer Brad Wolff declared that it was Denver's first "properly planned" subdivision. The homes were carefully sited on each lot to maximize outdoor space and privacy. The homes were all one story with carports and large back patios. The homes feature low-pitched roofs with wide-overhanging eaves, large windows overlooking the backyard and an open floor plan. These design features are all hallmarks of the Midcentury Modern style—and make Krisana Park stand out amidst a sea of Minimal Traditional Ranch homes in southeast Denver. Two years ago, Historic Denver worked with the neighborhood to identify the unique characteristics of the neighborhood. With a grant from the National Trust for Historic Preservation, we partnered with the Center of Preservation Research at the University of Colorado Denver to create the Krisana Park Pattern and Design Idea Book. This pattern book traces the historical roots of both the neighborhood and Midcentury

CONTINUED ON PAGE 3

Non Profit Org.
U.S. Postage
PAID
Denver, CO
Permit No. 756

Historic Denver, Inc.
1420 Ogden Street
Denver, CO 80218



FROM THE DIRECTOR



Photo: Havey Productions

BULLDOZERS have been making frequent appearances in neighborhoods across the city over the last year—and 2015 statistics confirm that there were more demolition permits issued in Denver than any other year since 2006, when Denver’s Landmark Ordinance was amended to provide a demolition review provision intended to identify potentially significant structures before their demise. Between January and October of 2015, 632 demolitions applications were submitted, as well as 105 Certificates of Non-Historic Status (CNH) applications. Of these 737 applications, 34 were considered potentially eligible for individual landmark status. By year-end, another six potentially eligible properties were posted as part of a demolition notice or Certificate of Non-Historic Status. This generated a lot of work for Historic Denver, and obviously a lot of concern in neighborhoods that struggled to respond.

The fast-paced nature of the current development cycle, and recent preservation controversies, have created confusion about the demolition review process, and particularly the role of the Certificate of Non-Historic Status. Since the beginning of 2016 this confusion has led more than one historic building owner to apply for a CNH when it was not needed, which causes unnecessary heartburn for both the owners and the community. As a result, Historic Denver has been working to create educational resources about the demolition review process, and the protocols community members can use to engage with property owners when a property has been posted as potentially eligible for historic designation as part of the demolition review process.

The Certificate of Non-Historic Status was created as part of the demolition review ordinance in 2006. It was intended to give property owners the option to gain certainty about a building’s potential for historic designation, even if demolition plans are not imminent. Unlike a demolition permit, a CNH is valid for five years and runs with the property, not the owner. During that five-year period the owner can pursue a demolition permit with no further historic review by city staff. A

CNH is granted if a building does not potentially meet two of out of the three required designation criteria (history, architecture and geography), or if it does meet those criteria and is posted for public notice, but receives no response (i.e. a designation application) from the community. A CNH is also granted if a designation application is filed but is not complete, or if an application is not approved by the Landmark Commission or City Council.

Despite its name, the CNH does not automatically mean that the property has no historic merit. Indeed, after the five year CNH period the property could be reconsidered for designation, or would at least be flagged again if a new CNH were filed.

However, the most common and practical reasons property owners may apply for a CNH are if: demolition is desired; a site is being marketed for sale as a scrape site; or as part of a purchaser’s due diligence if they are interested in scraping. In these circumstances the CNH allows the owner to “test the waters” and gauge the community sentiment about a particular building. Based on the community’s reaction, the owner can chose whether to proceed with the application despite objections and risk the controversy, or withdraw and pursue another avenue.

A CNH is absolutely not necessary if an owner simply plans to renovate a non-designated, potentially historic structure. A CNH is also not necessary if the owner plans to sell a site but believes it will be reused and remain intact. In these circumstances a CNH will only serve to create community concern and consternation, and invite unnecessary controversy.

But how does the community know if the CNH is a real threat? What actions can community members take to encourage a preservation outcome?

First, and most importantly, community members can contact the owner. An application for Non-Historic Status is a public document and anyone can ask the city for a copy in order to obtain accurate contact information. Because there can be varied reasons someone has applied for a CNH, including a misunderstanding about what the certificate is used for, a simple phone call can help determine the owner’s plans. This is also an opportunity to explain to the owner what is special about the building, and why the community cares. Finally, owners are not always aware of the various incentives available to help support property owners, and this first call can be used to begin a conversation.

Community members can, of course, also contact Historic Denver. In the current climate Historic Denver does not have the capacity to react to every demolition and CNH notice, but we do review them all and use our own internal evaluation to determine if action is warranted. One evaluation criteria we use is whether there is clear interest in the community, and whether there

are community members willing to be involved. We also consider the historic significance of the property, its “public benefit” in terms of the number of people likely to be affected by demolition, and the likeliness of finding an outcome or compromise that works for all parties.

Historic Denver never takes action related to a CNH posting, or a demolition posting, without first contacting the owner. In a number of cases this contact has resulted in a positive preservation outcome, with the owner voluntarily withdrawing the CNH application. For example, in 2015 Historic Denver saved five posted properties through communication with the owners and clarifications about the processes and options. This included a high profile “save” at 1899 York Street. More recently Historic Denver worked with the owner of 3064 Speer and 2822 Federal, and in both cases the owners withdrew their application so that they can learn more about preservation options.

In this heightened climate of frequent demolitions, it is easy to feel alarmed when a CNH application or demolition notice is posted on a property you care about. We hope that the protocols posted on our website can serve as a guide for community members, so that preservation is given every consideration. We also encourage community members to work proactively to foster preservation action, either through historic district efforts, or by giving a friendly call to the owner of your favorite local building and providing them with preservation resource information before major decisions are made. Resource information is available on our website in the “Resources” section.

Historic Denver recognizes that Denver is changing, and that demolition is not going away, but through positive and constructive action, we can ensure that Denver retains its important landmarks and unique character.

Annie Levinsky
Executive Director
Historic Denver, Inc.



HISTORIC DENVER, INC.

1420 Ogden Street
Denver, CO 80218
303.534.5288
www.historicdenver.org

BOARD OF TRUSTEES

Chair	Paul Books
Vice Chair	Larry Nelson
Vice Chair	Mark Davidson
Treasurer	Mira Finé
Bruce Allen	Carla McConnell
Elaine Asarch	Casey Miller
Stockton Baker	Kaydee Smith Myers
Bob Bassett	Jackie Noble
Hon. Karen Brody	Kirsten Pederson
Georgianna Contiguglia	Jonathan Pray
Dan Craine	Rebecca Rogers
Jane Crisler	Judi Roach-Tointon
Steve Ekman	Kendra Sandoval
Ellen Ittelson	Bob Sarlo
Jesse Kajer	Steve Weil
David Leuthold	Bill Wenk

HD CENTRAL OFFICE

Executive Director	Annie Levinsky x1
Outreach Coordinator	Shannon Schaefer x5
Director of Preservation Programs	John Olson x4
Director of Discover Denver	Beth Glandon x3
Preservation and Research Coordinator	Becca Dierschow x6
Development Associate	Sigri Strand x7

PRESERVATION ADVICE AND REFERRALS

A Program of Historic Denver 303.534.5288 x6

MOLLY BROWN HOUSE MUSEUM

1340 Pennsylvania St.
Denver, CO 80203
303.832.4092
www.mollybrown.org
Director Andrea Malcomb x15
Director of Education Jamie Melissa Wilms x17
Curator of Collections Stephanie McGuire x12
Volunteer and Event Coordinator Kim Popetz x16
Visitor Services Coordinator Aileen Waski x13

HISTORIC DENVER NEWS

Managing Editor
Becca Dierschow 303.534.5288 x6
Graphic Design Edgellworks
Printing Southeast Denver Graphics
Mailhouse Direct Mail Concepts

Historic Denver News welcomes your letters, contents of which may be edited for length and clarity. Please include your name, address and telephone number in correspondence to:
Editor, *Historic Denver News*,
1420 Ogden Street, Denver, CO 80218



CONTINUED FROM FRONT PAGE

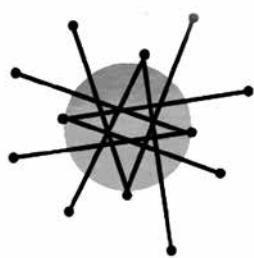

Modern architecture. It also surveys the existing homes in the neighborhood, revealing the six different floor plans found throughout the neighborhood, as well as the architectural characteristics featured on the homes. The pattern book helped neighbors articulate specific qualities they valued in their homes, and how those qualities were different from the more common homes around them.

The pattern book is intended to highlight the special features of Midcentury Modern homes and help neighbors find ways to sensitively remodel their homes to honor the unique character of the neighborhood. As Denver changes, the Midcentury Modern character of Krisana Park is being threatened by inappropriate pop-tops and the looming specter of full-scale demolition. Today's families may find the original 1200 square feet to be a tight squeeze, and the lack of garage a reminder of their home's advancing age. Fortunately, these homes were designed to be easily expanded. Some modern expansions, however, such as a full two story addition, negatively affect the historic character of the neighborhood and infringe on the prized privacy of the backyard next door.

As the neighbors worked with Historic Denver, they learned more about other tools they might use to protect the character of their neighborhood. As is typical, it can be hard to view middle class, post-war housing as 'historic' or worthy of preservation. Additionally, many neighbors didn't want the design review that comes with historic district designation. As such, a historic district wasn't the right fit for the neighborhood. Instead, a group of neighbors on S. Edison Way spent an entire year learning about conservation overlays, identifying the key features of their neighborhood that they wanted to protect, and working with the city to turn those features into zoning code language.

This ability to turn architectural characteristics into code is a key difference between single-use zoning and form-based zoning. Form-based zoning describes the general character of an area, starting at the neighborhood level and working down to the lot. The zoning code notes the common street and block patterns; building placement and location; building height; and mobility (i.e., the transportation options available in the area). These preexisting neighborhood characteristics serve the basis of the resulting forms proscribed in the zoning code.

The current zoning for Krisana Park is S-SU-D, which stands for Suburban - Single Unit - 6,000 sq ft lot. In the S-SU zone district, buildings can be 2.5 stories, with a maximum height of 30 feet. The code also dictates set back requirements based on lot size, and even contains some design standards such as requiring an entry way on the primary street façade to promote pedestrian access.

Krisana Park neighbors identified four characteristics they considered to be defining features of their neighborhood: placement of the homes on the lots to ensure privacy; low pitched rooflines with horizontal emphasis; low scale, single story or split level buildings; and subordinate additions. These identifying characteristics are subjective—one person's subordinate addition may stick out like a sore thumb to someone else. Because the neighborhood was not looking for historic designation and the resulting Design Review from the Landmark Preservation Commission, they needed to turn these characteristics into objective language and building forms that can be regulated through the zoning code.

The resulting conservation overlay targets five aspects of the building form and lot, to ensure that future developments or additions are in keeping with the Midcentury Modern character of the neighborhood. The maximum building height has been reduced from 2.5 stories to 1.5, or 18 feet, whichever is shorter. The maximum roof pitch is set at 3:12, which will maintain the low-slung character of the buildings. To maintain privacy in the expansive backyards, roof top decks are prohibited. To offset the edict against a full second-story addition, the zoning code has reduced the minimum rear set back requirement from twenty feet to fifteen feet. This will allow homeowners to build larger additions to the rear of the property. Only future additions or redevelopment projects will be required to adhere to the new zoning in the conservation overlay. Existing additions that do not meet the new standards are allowed to remain.

As neighborhoods throughout Denver work to identify and articulate their unique characteristics and decide the best ways to honor those traits, conservation overlays deserve a close examination. As a less intense alternative to historic districts, they are ideal for neighborhoods that want to encourage thoughtful redevelopment that is in keeping with wider neighborhood character. As Denver continues to feel the pinch of development across the city, conservation overlays provide an opportunity to recognize the micro-context of an area and to promote a fine-grain approach to development that is not always possible with standard zoning.

If you'd like to learn more about how communities and developers can plan for and build a lasting neighborhood, be sure to read our *Ten Principles for an Enduring City*. These principles are the culmination of our first annual re:Denver forum series, which wrapped up in April, and are featured on page 6. ✿

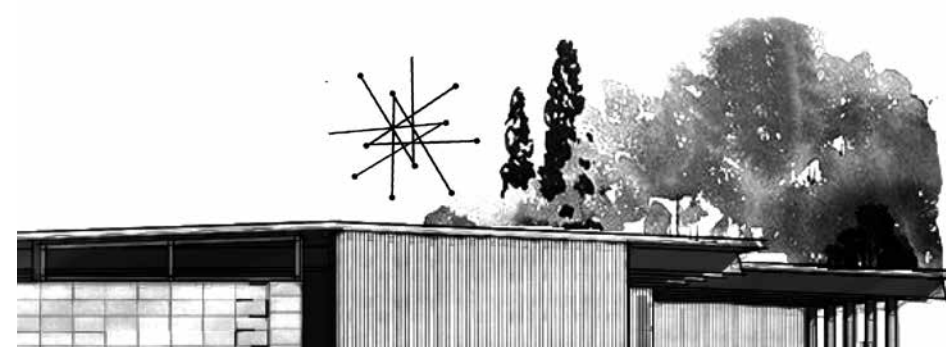

SIGN UP TODAY FOR OUR NEW LARIMER SQ. WALKING TOUR – WITH EXCLUSIVE ACCESS TO THE DANIELS & FISHER TOWER!

Beginning in May, Historic Denver will launch the Larimer Square Walking Tour, including an exclusive tour of the Daniels and Fisher Tower! This tour will explore Larimer Square “Then & Now,” learning about the foundation of Denver, the first settlement, the first post office, the first city core, which eventually fell into hard times turning into skid row. In time, it was resurrected by local citizens, led by Dana Crawford, who saved the block of buildings from urban renewal. The first Historic District in Denver, Larimer Square is now economically vibrant and preserved for future generations. The volunteer docents will lead tour attendees along the streets of Larimer Square, stopping to look at the beautiful buildings that were saved and hear the stories behind the walls. Then the tour will head over to another preservation success story and landmark, the Daniels & Fisher Tower. Here, guests will be allowed to visit the top of the tower and view the city from a new perspective. Tours last 90 minutes.

For tour times, days, prices and to purchase tickets, please visit historicdenver.org.

Members of Historic Denver receive a special member price.

Tours run May through October

Also check out our popular LoDo and Capitol Hill Walking Tours!

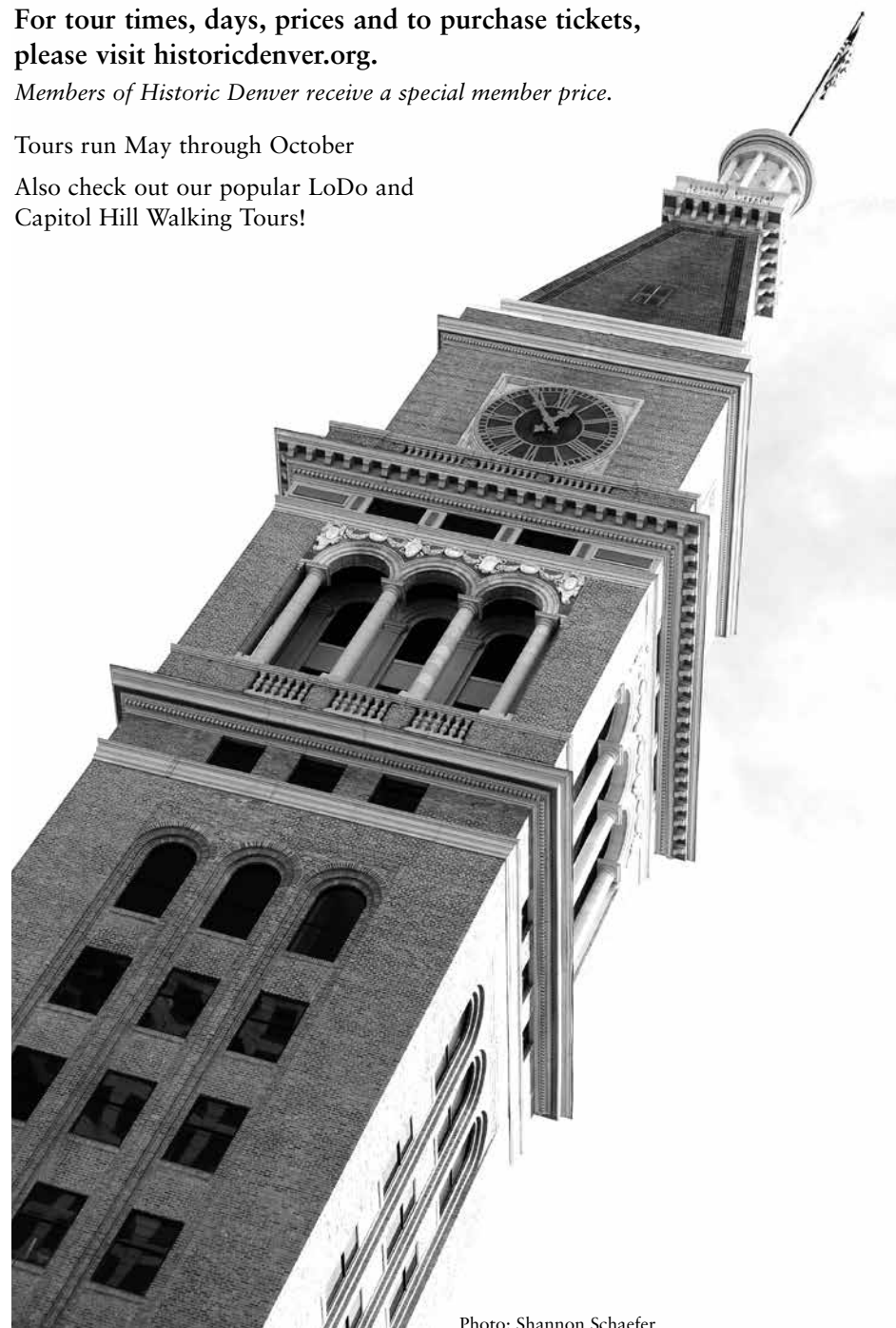

Photo: Shannon Schaefer

PRESERVATION BRIEFS



Photo: Denver Public Library Western History Collection

STADIUM ARENA GAINS LOCAL HISTORIC DESIGNATION

This spring, the City of Denver, following a recommendation from the Master Plan for the National Western Complex (2014), moved forward with a historic designation for the 1908-09 Stadium Arena. Approved by the Landmark Preservation Commission on March 15th, the designation went before City Council for a public hearing and a final vote on April 18th. Historic Denver has worked hard over the last five years to encourage preservation at the Stock Show site, and we were pleased to provide public testimony in support of this designation. City Council approved the designation with unanimous support.

The Stock Show Master Plan identifies the Stadium Arena, the oldest building constructed for the Stock Show, as a key historic building on the site. One of the stated goals in the Master Plan is to “honor the authenticity and origins of the site, preserving architecture and features that have historic and cultural merit, while efficiently reusing them and integrating with new facilities.” By making the Stadium Arena a local landmark, the city honors the historic legacy of the Stock Show, and will make sure that the new National Western Complex reflects that history through the built environment, giving all visitors a sense of the complex’s past, as they experience old and new events alike.

The Stadium Arena is one of Denver’s few intact examples of monumental Neoclassical style architecture outside of Downtown Denver. It is also an important and early example in Colorado of a steel skeleton agricultural arena building. At the time of its construction in 1908, the Stadium Arena was the first enclosed amphitheater to be built in Denver.

The Stadium Arena represents the historical development of Denver and Colorado and of the National Western Stock Show, one of the largest and oldest stock shows still in operation in the United States. It was the sole entertainment venue for the show until 1952, when the Denver Coliseum opened. Its original brick oval-shaped walls are largely intact, allowing them to be readily revealed as proposed by the National Western Center Master Plan.

The Stadium Arena contributes uniquely to Denver’s distinctive Western character.

It is strongly emblematic of Denver’s early history as a center of the livestock and meat packing industry at the historic Denver Union Stock Yards on the northern edge of Denver. The National Western Stock Show has historically been and continues to be a major economic event for Denver and Colorado, drawing farmers, ranchers, and tourists from around the nation. Historic Denver is glad to see the City of Denver formally acknowledging the historic importance of this building and protecting the legacy of the Stock Show for generations to come.



Photo: Denver Public Library Western History Collection

EMILY GRIFFITH LANDMARK DESIGNATION MOVES FORWARD

In late March 2016 Historic Denver and Denver Public Schools filed for historic designation of the Emily Griffith Opportunity School, located between 12th Street and 13th Street, Glenarm and Welton. The designation application is the result of more than three years of analysis, conversation and planning about this important historic site. It provides opportunity for both meaningful preservation and significant redevelopment.

These conversations were the result of community interest generated in 2012 when DPS announced its plans to move the school and sell the site, and applied for a Certificate of Non-Historic Status, which allows for demolition within a five-year period. Historic Denver received immediate response from community members, and asked DPS to consider a more in-depth process before moving forward, a process that would honor the DPS policy on historic schools, established in consultation with Historic Denver in the early 2000s. DPS agreed, withdrawing the CNH application and engaging in a thoughtful and deliberate effort to understand which buildings have the most historic value, how new development can also occur on the site, and how the old and new can work together to create a dynamic place that honors an important Colorado story while embracing downtown’s evolution.

The Emily Griffith site has been in public ownership for more than 150 years, first serving as a public school location in the 1870s. However, DPS granted Emily Griffith, who was serving as Principal at Crofton Elementary School in Curtis Park, permission to open a non-traditional school for “all who wish to learn” at the site in 1916. Based on her early teaching experiences Griffith recognized the needs of not only her students, but also their parents. Her first offerings at the Opportunity

#beHistoricDenver

For Historic Preservation Month of May

May is Historic Preservation Month! Historic Denver is expanding our efforts with Social Media by launching the #beHistoricDenver publicity campaign. Join the movement and tell us about your favorite historic places in Denver!

Use the hashtag #beHistoricDenver to post pictures and stories (on facebook, instagram and twitter) of your favorite places in Denver. Help Historic Denver tell the stories of Denver’s unique places and the people that made them significant. One place and one story at a time, you will be helping us weave together Denver’s diverse story. At the end of May, we will do a drawing from the submissions we received. One lucky winner will receive a Private Tour of our New Larimer Square Walking

Tour led by one of our expert docents. The Winner can invite up to five friends or family to join in on the fun!

BECOME A HISTORIC DENVER MEMBER IN MAY!

Follow Historic Denver on Facebook and find out more about membership and who we are on Membership Mondays. When you join Historic Denver and become a member in the month of May you will receive an additional month of membership (13 month membership), and new members will be entered to win a prize at the end of the Month! Stay tuned to our social media platforms and website to find out more details. *

FOLLOW US ON:

Facebook: Historic Denver, Inc.
Instagram: @Historic_Denver_Inc
Twitter: @HistoricDenver

*Grand prize drawing open to all who wish to enter, regardless of membership status. To enter without joining e-mail info@historicdenver.org with name and contact information.

School included English language courses, citizenship courses and technical training programs including bricklaying, carpentry and millinery. By the 1920s, the school was so popular that DPS invested in an expansion, constructing the building that now sits at the corner of 12th & Welton. It was expanded with two significant additions in 1947 and 1956, completing the build-out of the Welton Street side of the block and replacing the 1880s Longfellow School that Griffith had first used.

The original 1926 building was designed by E. Floyd Redding. The two additions were designed by Gordon Jamieson in the early 1940s. Jamieson was a notable modernist architect who once worked with Eugene Groves, and his designs were implemented over time as the school developed the resources for new construction. The 1926, 1947 and 1956 buildings are inter-connected and today are experienced as one building with multiple entrances. All three sections are four stories tall and constructed with Denver's signature red brick and terracotta. These buildings represent the most historically, architecturally and geographically significant aspects of the Emily Griffith site, representing the story of the school, Griffith's legacy, and the importance of the school site in the development of downtown Denver. The "Welton Buildings," as the interconnected structure has come to be known, are the "contributing" buildings in the designation application and are to be protected and preserved.

Gradually DPS also acquired land to the east of the original building and constructed a series of mostly one-story shops on Glenarm Place. While interesting in terms of their connection to the technical programs of the Opportunity School, the buildings have less architectural and geographical significance, and as a result the eastern portion of the block is deemed "non-contributing" in the designation application. On this portion of the site a future developer can build according to the Downtown zoning, downtown design guidelines, and a special set of site-specific guidelines intended to ensure compatibility and integration with the historic structures on Welton. There is no particular height limit in this section of downtown, as height is a factor of use and floor area ratio.

Additionally, the designation application defines a "transitional" area at the center rear portion of the Welton buildings where a connection to the new development to the east may be made. This connection can physically attach to the historic structures if needed, and partial demolition in this area is described as allowable in the application. However, the street view of the Welton Street Building from three sides will be carefully preserved and this transitional area, if used by a future developer, will be perceived as a rear addition to the original structure, stepping up to a potentially larger structure on the Glenarm side of the block.

DPS officially listed the property for sale the same week the designation was filed. The intention is for the designation and sales process to occur concurrently, with the designation becoming official before a sale closes. DPS has included information about the preservation provisions in a request for proposals from developers.

Historic Denver wants to offer DPS our appreciation for engaging us as a key stakeholder in this process and recognizing the importance of this place to our city's past and future. We also want to thank a trio of architects who helped DPS and stakeholders understand the site: Gary Petri of Hord Coplan Macht, David Tryba of Tryba Architects, and Joe Poli of Humphries Poli Architects. Finally, we want to thank the City of Denver Landmark staff and Director of Community Planning & Development Brad Buchanan for his support for a solution that involves preservation and quality development.

The Emily Griffith process demonstrates that property owners and the preservation community can work together to find solutions that make our city more unique, more rooted in its identity, and more adaptable for the future. We appreciate the great support of many community members who have advocated for the site and the process, and hope to see our members and friends at the public hearing at Denver City Council on May 16, 2016.



BLOCK OF LINCOLN STREET SEEKS HISTORIC DISTRICT

Homeowners in the 200 block of South Lincoln Street are moving forward with a local historic district on their block. The block encompasses fifteen homes built between 1889 and 1895, all of which embody Queen Anne architecture. One of these homes (227 S. Lincoln St.) was designated an individual historic landmark in 2015. William Lang designed eight houses on the west side of proposed historic district. The block is believed to be the largest collection of intact Lang-designed homes in Denver. Born in Illinois in 1845, William Lang moved around the Midwest before settling in Denver in 1885. It is not clear if he ever had formal training as an architect or was entirely self-taught. Either way, he had a prolific career in Denver, designing over 250 buildings, including the Molly Brown House, Castle Marne Mansion, and St Mark's Parish Church. All of the homes on South Lincoln Street have Lang's quintessential hallmarks of Queen Anne design, which often includes asymmetrical forms, steeply

pitched roofs, varying wall textures, wrap-around porches and turned porch spindles. As History Colorado's Architect Biography of Lang notes, "It is difficult to pin Lang down to a definite style, for he merged many elements from different styles to suit his taste, not following convention." Unfortunately, his career was greatly impacted by the Silver Crash of 1893. He declared bankruptcy after the crash and never recovered. He was diagnosed with dementia in 1897, and died the same year after being hit by a train. Though his career only spanned 8 years, his legacy as a gifted and inspired architect lives on in Denver to this day.

At the Landmark Preservation Commission public hearing on March 15th, the Commission gave its approval of the historic district application. It will now move forward to City Council, where it will be heard in a final public hearing on Monday, May 16th.



Photo: Paul Brokering

PLATTE TO PARK HILL STORMWATER SYSTEMS

On April 6th 2016, the City of Denver announced that, as part of the Platte to Park Hill Stormwater Systems project, the city would move forward with a plan to put a detention pond in the City Park Golf Course, as opposed to an alternative plan which would have placed the dry pond in the Cole neighborhood. This decision came after months of public meetings and an outpouring of neighborhood concern about the project and its ramifications. The City of Denver states that "City Park Golf Course was selected for water detention because it will protect significantly more homes and businesses; utilizes an existing city asset, reducing the need for private property acquisition; and creates better opportunities for future needed stormwater improvements."

Installing the detention pond in City Park Golf Course is certainly preferred over the demolition of dozens of historic homes in Cole. However, City Park Golf Course is on the National Register of Historic Places as a contributing resource to Denver's City Beautiful Parks & Parkway System. It is also the only Denver-area golf course listed on the National Register and has deep cultural significance in the Denver community, therefore this alternative must be carefully and thoughtfully discussed. The community must have the opportunity to review details and truly understand the impact before final design decision are made. As the project moves forward, Historic Denver urges great caution and care, and recognizes that the success of this type of project lies almost entirely in the details. We have seen suggested club house re-location options and have concerns about the preservation of the views from the east side of the course, as well as the preservation of the low-slung, expansive quality of the course, which is mentioned in the National Register listing.

The Platte to Park Hill Stormwater project will affect more than City Park—it also includes an open channel that will run through the Cole neighborhood to an outfall in Globeville Landing Park. As two of the proposed Platte to Park Hill Project sites are parks, Historic Denver would also like to note generally that our parks and open spaces are facing unprecedented demands to meet unanticipated needs. With community recreational and cultural use increasing, placing additional infrastructure demands on park lands must be done with great care and caution, as their value to the community is extremely high, their place in the city's identity is unmatched, and our ability to create new spaces of their size and quality nearly impossible.

In a rapidly changing city, our touchstones, landmarks, and beloved spaces are more important than ever. Historic Denver submitted formal comments to the City about the proposal in May, and will continue to participate to ensure the preservation and consideration for impacted historic resources. #





re:DENVER

Interactive Forums on Denver's Past, Present & Future



HISTORIC DENVER'S PRINCIPLES FOR AN ENDURING CITY

HISTORIC DENVER launched the re:Denver forum series in 2015 to explore issues impacting the past, present and future of Denver's built environment as our city evolves. We hosted forums on the quality and compatibility of infill development, Denver's unique character and urban attributes, design review and design guidelines, finding the right "forms" for our existing neighborhoods, real estate market forces, and urban design and the public realm. Both local and national speakers shared insights on what is happening today, and what we could be doing differently as a city to ensure that Denver retains its quality of life and character as it grows.

During the forums we heard over and over again that community identity — the identity created by our built environment and the way we as humans interact with it — matters. It matters from a quality of life perspective, it matters from a walkability and human scale perspective, it matters from an environmental sustainability perspective, from a durability perspective, and yes, from an economic perspective. Historic Denver has taken what we've learned from the re: Denver forums, attended by more than 400 community members and professionals, to create Historic Denver's Principles for an Enduring City. These principles are designed to ensure that Denver remains a great place to live, and grows in a way that is sustainable and long-lasting so that the city we enjoy today is still here fifty years from now, including the buildings we'll build in this boom cycle and the next. The principles are intended to inform change, not halt it, and to recognize that we are building in a specific place — a place with character, a place with rhythms and patterns, a place with history, and a place that owes much of its success to the qualities embodied in our unique identity.

1. KNOW AND ARTICULATE WHAT MAKES DENVER...DENVER

In order to accentuate our city's unique character and to encourage compatible construction, we as a community need to know what that character is and be able to explain it to architects, developers, planners, policy-makers and other community members.

The common and frequent attributes that define our city include warm and organic building materials such as brick, stone, stucco and terra cotta. Buildings should be oriented with the sun in mind — and employ architectural features like overhanging eaves and porches to capture the sunshine and big sky Colorado is famous for. On the neighborhood scale, embedded commercial/mixed-use districts enhance the walkability and economic vibrancy of our local communities. Those neighborhoods, in turn, are unified by a common thread of parks and parkways which run throughout the city.

2. INFILL BEFORE REFILL



As a result of the urban renewal initiatives of 1960s and 1970s, Denver has a lot of vacant land. We should consider how to encourage and direct development to these spaces, rather than in places where historic buildings and patterns exist.

A 2004 report from the Brookings Institution projects that by 2030, the country anticipates demolishing nearly 1/3 of our building stock. That's a staggering number and it raises significant questions not just about historic buildings and architecture, but also about sustainability and our environment. Recent calculations indicate that it takes 35–50 years for an energy efficient new building to save the amount of energy lost in demolishing an existing building. We can and should understand the volume of our vacant lots and their combined buildable potential based on current zoning. How many residential units could we build without losing a single historic building? How many vacant or underutilized buildings could be retro-fitted for new or mixed uses?



3. SHARED SPACES MATTER

Character and identity come from the spaces we share, the public realm. Urban design is as important, if not more important, than architectural style.

These spaces, the collective public realm, must be valued by our residents, the design community, and local policy. What makes for a good public realm? Walkability, a sense of safety, welcoming building façade, transparency and 'visual harmony'. Visual harmony is not the same as uniformity or monotony, but it is a consistency, a pattern. Buildings with doors facing the street, cared-for public right-of-ways, transparency and a sense of 'lived-in' or 'worked-in' spaces all support the public realm and our human experience of the street.

4. SUBSTANCE OVER SPLASH

Not all buildings need to stand-out, and quality background buildings reinforce rhythms and patterns and reflect a quality that lasts, as opposed to a "trendy" quality.

Quality background buildings are the backbone of the city because they reinforce rhythms and patterns of the street, embodying a simple sense of quality and durability. Background buildings, regardless of style or age, have a quality that lasts.

5. TREAT GREEN SPACE AS A UNIFYING THREAD

Denver's most popular neighborhoods are oriented around parks and parkways and connected by "green-strips," symbols of the City Beautiful vision — a vision that believed design and beauty had the power to improve lives.

One of the most important components of the public realm, especially in Denver, is the relationship to green space. These spaces are not accidental, in fact they are the most prominent symbol of Denver's earliest city planning efforts, based on the City Beautiful vision. The parks and parkways were laid out and designed to connect important places and neighborhoods. The parkways frame our neighborhoods, buildings, and shared spaces. We must not only protect these official public spaces, but also remember that Denver's ubiquitous tree-lawns — found throughout the city, between the sidewalk and the street — matter too. They are the places where public meets private and we are collectively responsible to our neighbors and community to honor this piece of our character.

6. REFLECT RHYTHM & RELATIONSHIP

Denver is a city of neighborhoods, and each neighborhood has unique attributes, context and patterns that have value.

One size does not fit all and zoning is by nature a blunt tool. So we must find new ways for buildings to acknowledge their unique space in the world, and their relationship to their surroundings. Each neighborhood, and in some cases, each block, has its own rhythm, its own pattern. We can use the preservation concept of ‘character defining features’ to help neighbors and developers understand an area and build to its strengths.



7. DURABILITY + ADAPTABILITY = SUSTAINABILITY

Being sustainable is more than being “green,” and to build a sustainable and resilient city we must encourage quality building, durable materials, adaptability and people-centric places.

One thing we like to tout about Denver is our relationship to the environment. We like to think of ourselves as a forward thinking, sustainable city. Not only is the adaptive reuse of buildings a sustainable strategy, as demonstrated so successfully in LoDo, so too is constructing buildings that will last, that will not require constant replacement, and will certainly not be replaceable within one generation. Planned obsolescence should not find its way into our built environment.

An emphasis on materiality is, therefore, about more than design or aesthetics, it’s about durability. The old brick buildings of LoDo were built for a wide variety of purposes, almost none of which they serve today. But their solid construction, quality materials and adaptable nature make them valuable more than a century after their construction.

8. FOSTER THE FINE GRAIN

Mixed-use areas with diverse building age, size and use are critical to a city’s vibrancy and vitality.

Using a fine grain approach, sometimes called incremental development, we can add density and accommodate growth without sacrificing the places that make our neighborhoods desirable and livable. For example, street car commercial districts tend to “punch above their weight class” in terms of density and intensity of use, with active daytime uses, integrated residential components, and vibrant nightlife.

There is also increasing interest in the concept of “missing middle” housing and the importance of building and supporting a variety of housing types. There is historic precedent for this in our neighborhoods, with imbedded courtyard apartments, duplexes, small apartment buildings and single-family residential structures all compatibly co-existing. There are ways we can add options with a fine grain touch — as opposed to adding it only through bulk and height.

As Denver continues to face an affordability crunch, the fine grain can also provide solutions and new policies and programs that seek to support affordable housing should look to the preservation of existing and diverse housing options as a key strategy.



9. ENCOURAGE ADAPTABLE PARKING STRATEGIES

Design decisions are often shaped by expectations for parking, but can we identify more flexible strategies?

Whether required by zoning or simply seen as a market necessity, parking is driving design decisions and these decisions will be difficult to reverse over time. If parking is a primary, structural component of a building, how will we reuse it decades from now when driving habits or car technologies shift?





10. CULTIVATE A COMMUNITY ETHIC

Creating a culture that values a sense of place, urban character, and design quality is an important part of building an enduring Denver.

Having conversations about preservation, urban design, architecture and building quality is important, and this is the underlying reason Historic Denver started re:Denver. We need a forum to talk constructively about how our city is changing, and how we can support its character and its growth. We need a constituency that cares, gets educated, and advocates. Historic Denver will continue to host re:Denver each academic year, and will be releasing tools and ideas to support the principles, but we hope community members and partners will also take up the mantle.

If you find these principles useful, share them! You’ll find them on our website at www.historicdenver.org, along with recordings of our re:Denver talks and power point presentations. Share them with your neighbors, your friends, and your city councilmembers. Let them know that you value an enduring city, and encourage them to get engaged! Be sure to join us again in the fall when we debut our next re:Denver series. ✨

Your Choice for Historic Denver

Bonnie Boyer 303-870-5440 Theo Boyer 303-748-6944 Scott Boyer 303-931-2119

The Boyer Group, with over 40 years of experience, specializes in historic Denver real estate. They welcome your call if you are seeking a smart investment or if you would like to know the current value of your property.

Each Office Independently Owned and Operated



CASTLE LION DEVELOPMENT

Elegant “Turn-of-the-Century” Condominiums, Apartments & Townhomes for discerning clients.

❖

DARIA CASTIGLIONE
303-587-5471
DARIA@CASTLELIONDEVELOPMENT.COM

MOLLY BROWN HOUSE MUSEUM

THE HUMAN SIDE OF EVERY STORY

BY BROOKE TRAYLOR AND JARED GREGORIO, MUSEUM EDUCATION INTERNS

During the 1890s, Denver was known as the Queen City of the Plains. In hopes of becoming comparable to the likes of Chicago or San Francisco, Denver began to establish itself as both an important thoroughfare and place to live. Thousands were moving to the growing city, including JJ and Margaret Brown. They, along with their two children, moved to Denver in 1894.

The Brown's new residence was elegant. The Queen Anne style home located at 1340 Pennsylvania Avenue was located in the popular and up-and-coming Capitol Hill neighborhood. Built by notable Denver architect William Lang, the three-story house had four fireplaces, two large lion statues guarding the front of the house, and boasted new and modern technologies, including electricity, central heating, indoor plumbing, and a hand-crank telephone. There was also a carriage house at the back of the property. This, of course, is the Molly Brown House Museum today.

Despite the popular belief that Margaret and JJ were shunned by Denver's high society, they were very much part of it. In fact, from 1894 to the early 1920s, "the Browns took up more space in Denver's society pages than nearly any other Denver family". As Denver grew, high society began to thrive, and the Browns were very active in the world of Denver's upper class.

JJ and Margaret would have enjoyed luncheons, parties, and other social events on a regular basis. The famous Brown Palace Hotel on 17th Street was completed in 1892, and it was a popular place for tea parties and luncheons to be held. The Browns were regular visitors. Margaret also held numerous fundraisers in the hotel for some of her favorite causes, including for the Humane Society and select Catholic charities, among others. It is important to note that there is no connection between Margaret Brown and Henry Cordes Brown, the hotel's founder.

The Browns often attended the theatre and the opera as well. They regularly received visitors and hosted guests at their home in Capitol Hill. Like several other upper class families in Denver, the Browns also had a country home (now in present day Lakewood), where they hosted and entertained guests. Those attending these country retreats often considered their visit to the Brown's house a 'highlight' of the summer season.

Both JJ and Margaret also played prominent roles in Denver's business and political circles. JJ owned and worked at a mine management business, and Margaret was often busy either studying humanities and learning new languages,



Judge Benjamin Lindsey, often known as Denver's "Kids' Judge" for his pioneering reform of Denver's juvenile court system. Photo: Denver Public Library Western History Collection

or advocating for several political causes. The Cathedral Basilica of the Immaculate Conception on Logan and Colfax Avenue was built to serve the Denver community, and JJ and Margaret Brown were instrumental in raising money for its completion.

Margaret Brown is also well known for her progressive and liberal ideologies regarding a wide array of issues. Topics ranging from education, women's suffrage, labor rights, judicial reform, and gender equality. While serving as a champion for these causes throughout Denver, Colorado, and the world, Margaret often worked with and socialized with others who believed in such progressive causes.

One such prominent crusader was Justice Benjamin Barr Lindsey, founder of Denver's Juvenile Court (with Margaret Brown's help), and

the namesake behind Denver's current Lindsey-Flannigan Courthouse. Margaret and Justice Lindsey's similar views regarding youth justice reform and their work together has been well documented. So similar, and not to mention boisterous about their passions, were Margaret and Justice Lindsey that before they first met at a Denver dinner party the host remarked "Mrs. Shafroth and I had a wager as to which one would out-talk the other."

Youth justice reform was only one of Margaret and Justice Lindsey's causes. The two were also both strong proponents of gender equality. Justice Lindsey in particular advocated for equal rights to be shared in a marriage and for both parties to have a say regarding procreation, child-rearing, and even divorce, all of which were very taboo subjects during the period. Lindsey was so committed to these ideals that in 1927, along with coauthor Wainright Evans, he published "The Companionate Marriage" a book that outlined the principles and structure of marriage and gender equality that Lindsey so strongly believed in.

For Lindsey, "The Companionate Marriage" was a way for him to outline in legal terms, social and private concepts that he believed were ready to be implemented throughout America. In the introduction of the book Lindsey defined a companionate marriage as "legal marriage with legalized birth control, and with the right to divorce by mutual consent for childless couples, usually without payment or alimony."

These principles, blasphemous for a majority of the country and for many of Lindsey's readers, were met with strong criticism. Lindsey most certainly was prepared for this criticism, as he had dealt with critics his entire life. Many detractors argued that the points made by "The Companionate Marriage", and the very idea of a companionate marriage would lead to an ethical weakening of marriage and the country. The veteran judge, however, believed the opposite.

By making marriage equal and transparent, Lindsey argued, the institution would be strengthened and that millions of marriages would be turned into a mutual partnership of trust and respect. Lindsey so believed in his ideas behind restructuring marriage that he argued he could greatly decrease America's divorce rates, outlining a new method of divorce proceedings and couples therapy,

A lawyer, as a judge, would be required to by present laws and constitutions of the state but with him would be added scientific experts and specialists in human conduct and behavior... it would be open and freely accessible to all classes of discordant couples. Its proceedings would be confidential. I firmly believe it would succeed in getting at least one third of them to change their minds instead of their mates.

Lindsey's companionate marriage was too radical for his contemporaries and never came to fruition in his lifetime. In fact his adamant adherence to preaching for companionate marriage would go on to hurt him, bringing him national attention and often times infamy, contributing to his eventual disbarment in 1927. In fact a Time Magazine article from July 11, 1927 remarked that Lindsey "has become to many thousands of his countrymen a radical, a lunatic, an attacker of the sanctity of the home, and advocate of free love and of birth control."

While Justice Lindsey did not see changes to the status quo in his lifetime, it is impossible to not see the threads of his beliefs in contemporary America's commonly accepted norms regarding the concept of marriage and gender equality.

Make more connections between the issues of our day and those of Mrs. Brown's, often the same at: mollybrownbtl.wordpress.com #

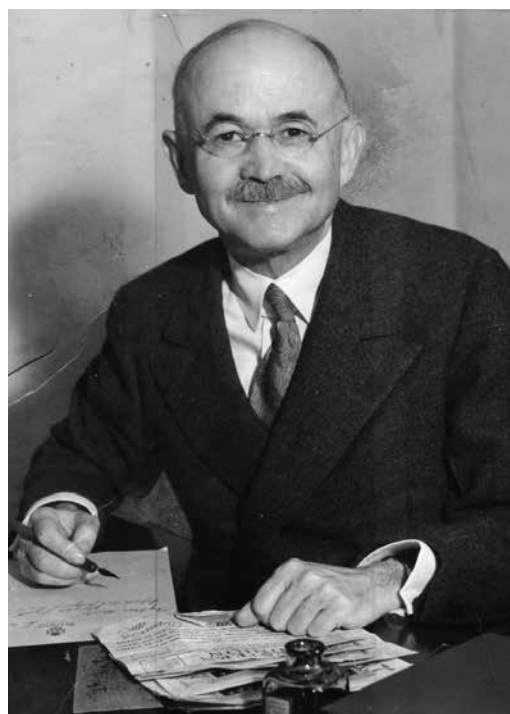

Photo: Denver Public Library Western History Collection

Our New Philanthropist
 So Mrs. Brown has leased a mine
 To help the youngsters! Well, that's fine
 All that it makes will go to aid
 The juveniles! When it has paid
 Enough to build a club house, then
 There'll be one for the "little men"
 In whom Judge Lindsey takes delight,
 And "kids" will call it "out of sight!"

I doff my hat to Mrs. Brown!
 Philanthropy is scarce in town!
 Not scarce, perhaps, but it might be
 Far more abundant here, and we
 Would never mind it! May the scheme
 Prove more substantial than a dream!
 May this one mine, at least, yield gold—
 More than the rest—an hundred fold!
 —The Observer.



The homes on River Drive often use unique methods to compensate for the hilly terrain. This home has a large staircase leading to the front door, creating a large garden level apartment below. Photo credit: Denver Public Library Western History Collection.

JEFFERSON PARK'S HIDDEN GEM: RIVER DRIVE

ANDREW GANZ, VOLUNTEER WITH DISCOVER DENVER

Slicing through Jefferson Park, River Drive is an oasis in the city, standing out not just because the northwest-southeast-running street doesn't conform to a mapmaker's grid. With houses of nearly every style dating between the 1880s and the early 20th century, River Drive remains remarkably preserved and intact—something one certainly cannot say for the rapidly-changing Jefferson Park neighborhood that surrounds it. As you might expect, there are plenty of stories that this short stretch of pavement can tell us—and many that may surface again.

Prior to the arrival of I-25, River Drive snaked down the hillside to the Platte River that gives the street its name. But the only thing flowing on River Drive was the beer brewed at the nearby Zang and Tivoli breweries. Zang Brewery, located on nearby Water Street, was the successor of the first brewery in Denver, the Rocky Mountain Brewery. Phillip Zang, an immigrant from Barvaria, via Kentucky, originally started out as the manager of the brewery, using his previous brewing experience to quickly become indispensable to the company. Zang bought it out in 1872, changing the name to the Zang Brewery. While Philip died in 1899, his son Adolph carried on operations until 1913. What started out as a 2,000 barrel operation became Denver's largest brewery, producing nearly 175,000 barrels a year at the height of production. Prohibition, however, proved to be disastrous for the brewery, which shuttered in 1927. The site of the brewery is now home to the Denver Aquarium, although two related historic buildings remain on Water Street.

Zang hired Theodore Beck to be head brewer in the 1880s. Today, the Beck House sits at the end of River Drive, where it is still possible to view what's left of the Zang Brewery on the other side of the interstate. Current homeowner Jeff Rodgers is well immersed in his home's folklore. Evidence remains of what may have been a Prohibition-era tunnel connecting his home's basement to that of a nearby tavern. The tavern is long gone, but it was located across an alley where the Element 47 apartment complex sits today. Further, owners of Jeff's house have passed down ledgers from the 1920s indicating painstaking record-keeping of items related to the 'oil and gas' business. In Prohibition-era Denver, this meant one thing: bootlegging.

Above ground, what stands out perhaps the most about River Drive is the way that otherwise standard home designs were adapted to the road's unusual grade. A newspaper report from 1898, when the houses were just a handful of years old, referred to the road's grade as "precipitous," and the Queen Anne homes were built

with unusual entrances. A trio of houses colloquially known as the "three triplets" all built around 1890 are located toward the northwest end of River Drive. Each features a different take on the modified entrance look. Late 19th century photos of some of the houses are part of the Denver Public Library's collection and they reveal that the houses remain largely unchanged today. The first two have sunken front porches that could almost be called subterranean, being a few steps below road level, while the third marries Queen Anne architecture with a half dozen steps up to its new porch.

Walk a few houses down the street, closer to the Platte River, and three more houses appear to be pushed into the earth. A terrace-style, two-story quadplex, like those built in so many other parts of Denver, is also half-sunken, creating a European-style garden apartment. However, the unusual bridges required to access its second floor units from the street hardly look original, so a more thorough study of the building's past may be due.

The street was graded in its current configuration in the 1950s, supposedly when new pipes were buried to address drainage issues of what is possibly Denver's most uneven street. The original flagstone has since been replaced by a narrow concrete sidewalk. At the time, or at least not long after, many of the street's homes were owned by members of the same family. Although the family has since moved on from the neighborhood, long-time resident Joan Bondy recalled that units of the family would routinely swap houses between each other. That sort of camaraderie remains on River Drive today, which stands as something of an island in modern, boxy Jefferson Park. Even a quick jaunt down this hidden gem reveals a full tour of late 19th and early 20th century architecture. If you didn't know better, you could be forgiven for thinking that the buildings had been relocated to this angled stretch of Northwest Denver in order to give passersby a glimpse of 'old Denver'.

In every neighborhood throughout Denver, there are carefully preserved pockets like River Drive—streets that tell the stories of our past. Historic Denver's Discover Denver survey project is working to capture these stories, one neighborhood at a time. By identifying the significant places of our past, we can promote community pride and encourage reinvestment in our future. To learn more about Discover Denver, please visit www.discoverdenver.CO. #

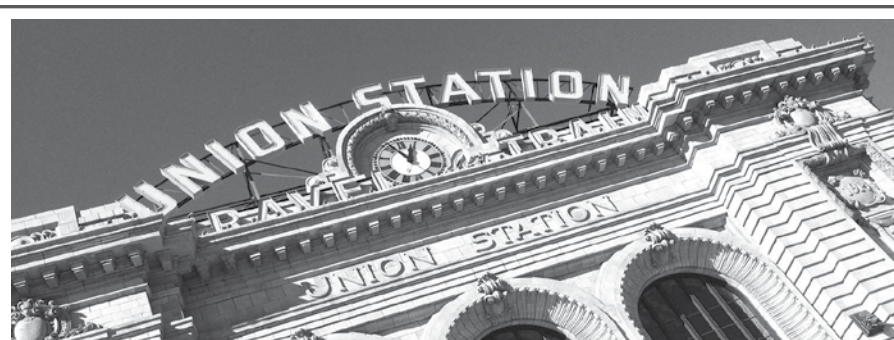

CELEBRATING DENVER'S HISTORY

With a heritage that reaches back more than 100 years, Lewis Roca Rothgerber proudly supports the preservation of our colorful past.

Mark A. Davidson
MDavidson@LRRLaw.com
303.628.9577

LEWIS ROCA
ROTHGERBER

Albuquerque | Colorado Springs | Denver | Las Vegas | Phoenix | Reno | Silicon Valley | Tucson

LRRLaw.com

Stone restoration and refurbishment. Haddonstone's meticulous care and attention to detail has earned the company a reputation for the provision of stonework for the restoration and replacement of stone damaged by exposure and neglect. View our standard designs **online** or **call** to request a catalog or discuss your project.



32207 United Avenue
Pueblo CO81001
haddonstone.com
866 733 8225
Made in the USA



Preserving the Integrity & Functionality
of Historic Chimneys since 1980
Commercial & Residential
Ask Us About Our Free Inspections
RockyMountainChimneySolutions.com

303-946-9990
Only licensed Thermocrete
installer in Colorado

NOTABLE HOMES FOR SALE



1724 GAYLORD STREET

This home provides a rare opportunity to acquire a magnificent property in City Park West. Built circa 1904 by Simmons & Wolf, the home was designed by architect G. H. Huntington. The original owners were Gilbert H. Denton of Gilbert H. Denton Iron Works (later Vulcan Iron Works) and his wife, Anna. This property has not been available since 1973, and has been lovingly maintained, beautifully remodeled, expanded and fully updated with a design by architect Tom Morris. With a nod to classic 3rd floor ballrooms, the 3rd floor is spacious and open. With over 6,000 finished square feet and one of the most beautiful Linden trees in Denver, it offers a perfect Live/Work opportunity.

Original features include built-in oak bookcases, quarter-sewn oak staircases, and stained glass windows.

Home is located in a current enterprise zone within walking distance of City Park/ Zoo/Museum of Nature and Science, Vine Street Brewery, St. Marks Coffee Shop and many great restaurants along 17th Ave., East High School, Esplanade Farmer's Market, the upcoming Carla Madison Recreation Center, Tattered Cover and Botanic Gardens. Only about a mile from Downtown, The Brown Palace, Cherry Creek Mall, Denver Public Library and Sprouts Grocery.

Listing Price: \$1,300,000

Listing Brokers: Rhonda Knop, Distinctive Properties
303.523.3855, rhonda@distinctivedenver.com and
Cheri Ferbrache, CF Properties, Ltd
303.321.1285, cfprops@ecentral.com.

OTTENJOHNSON
ROBINSON NEFF + RAGONETTI

ottenjohnson.com

Deep roots reach higher.

Developing deals, navigating complex regulatory hurdles, responding to disputes, growing an enterprise – experience the difference that law elevated makes.

▪ REAL ESTATE	▪ FINANCING	▪ EMINENT DOMAIN
▪ REGULATORY COMPLIANCE	▪ TAX	▪ RESTRUCTURING
▪ BUSINESS TRANSACTIONS	▪ WORKOUTS	▪ BANKRUPTCY/ FORECLOSURES
▪ LAND USE & ENTITLEMENT MATTERS	▪ URBAN RENEWAL & PUBLIC/ PRIVATE PARTNERSHIPS	▪ COMMERCIAL LITIGATION

950 17TH STREET, SUITE 1600 | DENVER, CO 80202 | T 303.825.8400 | F 303.825.6525

*Rich in History.
Enduring in Style.*

LARIMER SQUARE

Denver's most historic block.
LARIMERSQUARE.COM

HISTORIC PROPERTIES *deserve an EXPERT*

CASEY MILLER
DENVER'S HISTORIC HOME EXPERT

Successfully Selling Denver's Historic Homes

Pictured Above: The Richthofen Castle in Montclair, Sold by Casey in 2012.

Fuller | **Sotheby's**
INTERNATIONAL REALTY

Casey Miller 720.201.2755
casey.miller@sothebysrealty.com
CaseyMillerProperties.com

THE INFINITE POSSIBILITIES OF ONE

ONE IDEA, ONE PERSON, ONE FIRM
CAN MAKE A DIFFERENCE

BROWNSTEIN HYATT FARBER SCHRECK
is proud to support Historic Denver and their work
to preserve Denver's distinctive historic places.

One organization. One person. One idea.
Can make a difference.

**Brownstein Hyatt
Farber Schreck**

Learn more at bhfs.com

Adam Agron, Managing Partner
Brownstein Hyatt Farber Schreck, LLP
303.223.1100 DENVER OFFICE
410 Seventeenth Street, Suite 2200
Denver, CO 80202

Thank You

TO HISTORIC DENVER'S NEW AND RENEWING SUPPORTERS

SUPPORTERS JANUARY TO MID-APRIL 2016

- | | | |
|-----------------------------------|-------------------------------------|------------------------------------|
| France Addington-Lee | Timothy Hepp | Nancy and Gene Richards |
| Dorothy Ambler | Bev Hiller | Mark Rodman |
| Darrell Arndt | Tony and Karen Hinkel | Ryan Rose |
| Frank Martinez and Marci Auston | Sarah Hite | Sharon Ryan |
| Gordon and Gerri Baron | Mary-Kate and Chris Hogan | Brenda Sabo |
| Diane and Paul Behm | Cathy Holland | Sandra Scherer |
| Kay Berenbaum | Nancy and Gary Holt | Ruth Schoenig |
| Anne and Brooks Bond | Donna and Larry Hoppe | David Shaw |
| Bill and Cynthia Braden | Barbara Hughes | Rhonda and Jeffrey Skallan |
| Pamela Bradley | Kathy Knight and Richard Hughes | Christine Barton and Davyd Smith |
| Virginia Broadus | Marijane Hutchison | Elizabeth and John Smith |
| Sue Bruner | Sylvia and Robert Jespersion | Michele Sorenson |
| Julie C. Van Camp | Nathan Church and Mindell Johnson | Maris Sovold |
| Constance KiKi Cannon | Stephanie and David Johnson | Jeannine Spicer |
| Penelope Carlevato | Ann L. Jones | Elizabeth Spohn |
| Jill Carlier | Steve Turner and Steven Kick | John and Mary Steinle |
| Castle Lion Development | Rita King | Arianthe Stettner |
| Hugh Grant and Merle Chambers | Lindsay A Kithil | Vincent Szafranko |
| Barbara Chapman | Barbara Knight | Brian Taylor |
| Stephen Chiles | Jamie Vizmanos and Loong Koon Goh | John Coniff and Wayne Thrash |
| Jon and Carol Connor | Sarah S. Krause | Diane Travis |
| Williams Court | Betty and Warren Kuehner | Erika Trigo |
| Linda Ferguson-Cox and Donald Cox | Christopher Lane | James Gehres and Margie Valdez |
| CRL Associates Inc | Lam La Lane | Rita Berberian and Tyron Vincent |
| Robert and Barbara Danos | Steven Lang | Tommy Visconsi |
| Gayle Deane | Linda Levin | Deborah Wagner |
| James Dosen | Ann Leviton | Jane Wainwright |
| William and Sue Dunn | Julian J. Lineham | Robert Walcott |
| Jenni Dyman | Hanna Loberg | Charlie and Valerie Walling |
| Victoria Eppler | Ashely Mains Espinosa | Carol Warner |
| Mona and John Ferrugia | James Martin | Tobi Watson |
| Barbara Ford | Byron and Judy Matson | Kelly Wemple |
| Alan and Sally Gass | James and Marsha McNally | Halie Werge |
| Greg and Toniea Gates | Patricia Mead | Stacy and Ben Wheeler |
| Brenda Geist | Kenneth Miller | Mary Ann Watson and Flint Whitlock |
| Thomas J. Giovale | Patrick Caldwell and Mary Kay Myers | Joseph and Barbara Wilcox |
| Susan Glassmacher | Steve Nissen | Dorothy Wilson |
| Kate Freed and John Goggin | Dan and Joyce O'Donnell | Tom Wilson |
| Cindy Gonzales | Gerrie Olthof | Sadie Wilton Gould |
| Laura Barry Hamilton | Margaret Park | Ann Wolff |
| Linda and Charles Hamlin | Marie Patterson | Jana Wu |
| Thomas J. Hammond | Lois Paul | Ray Wulf Sylvester |
| Deborah and Tom Hart | Steven Perez | Sheryl Wylie |
| Duke and Pam Hartman | Steven and Denise Perkins | Donald Zielesch |
| Karen Harvey | Carla McConnell and Jim Perlberg | |
| Polly Hays | Robert Peterson | |
| Kevin Henderson | Darrin Reivous | |

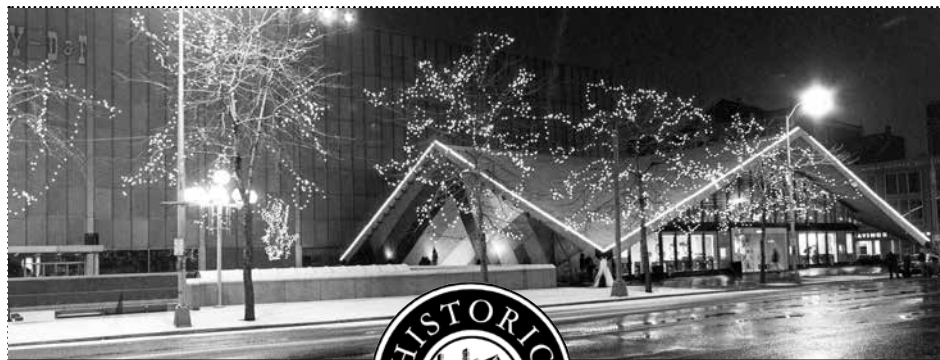

HISTORIC DENVER/MOLLY BROWN HOUSE MUSEUM MEMBERSHIP

Yes! I would like to become a member at the following level:

- Basic Senior Individual ~ \$25 (65 & up)
 - Individual ~ \$45; Teacher/Student ~ \$35
 - Dual ~ \$65; Senior ~ \$55
 - Family ~ \$80; Senior ~ \$70
 - VIP Associate ~ \$125; Senior ~ \$110
 - VIP Contributor ~ \$250; Senior ~ \$225
- I would also like to make an additional donation of \$_____.

Name(s) to appear on membership card(s): _____

Address _____

City _____ State _____ Zip _____

Phone _____

Email _____

Check Credit Card: Visa MasterCard AmEx Discover

Card Number: _____ Exp. Date: _____

Verification#: _____ Total: \$ _____

Signature: _____

Please make all checks payable to Historic Denver, Inc.

Historic Denver is a 501c3 organization and a portion of your contribution is tax deductible.

Please visit historicdenver.org/support to learn about the benefits at each membership level.

Trusted Relationships.

We help our clients tackle business issues best by working closely together.

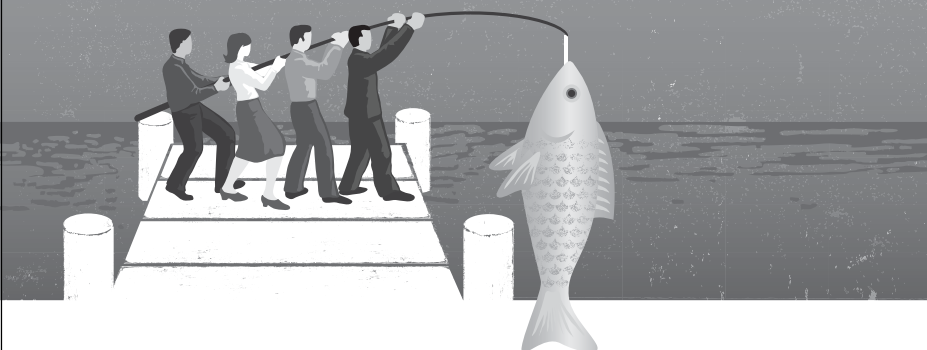

At Hein & Associates LLP, we believe success is the result of our people and clients sharing knowledge, working effectively in teams, and sustaining long-term relationships to achieve goals.

For more information, visit www.heincpa.com or contact Mira J. Finé, Partner, National Director of Tax Services at mfine@heincpa.com or 303.298.9600.



CERTIFIED PUBLIC ACCOUNTANTS AND ADVISORS
DENVER | HOUSTON | DALLAS | ORANGE COUNTY

Denver's Source For Complete Commercial Real Estate Solutions

We have shaped the Denver commercial real estate landscape by providing solution-driven, innovative and decisive services to the community through our relationship-driven approach.

Our services for Office, Retail, Industrial and Land include:

- | | |
|-------------------------|-----------------------------|
| Tenant Representation | Investment Sales |
| Landlord Representation | Valuation & Advisory |
| Seller Representation | Property Management |
| Buyer Representation | Commercial Property Lending |

Realizing Potential. Delivering Results.

NAI Shames Makovsky
Commercial Real Estate Services, Worldwide.
www.naishamesmakovsky.com

(303) 534-5005
1400 Glenarm Place, Suite 100
Denver, CO 80202

CALENDAR OF EVENTS

To purchase tickets to upcoming events visit mollybrown.org. Events are held at the Molly Brown House Museum, 1340 Pennsylvania Street, Denver.



THURSDAY MAY 12

DOUBLE ENTENDRE
6:00 - 8:00 pm | \$20
Molly Brown House Museum
1340 Pennsylvania

"Birds do it. Bees do it. Even educated fleas do it. Let's do it! Let's..." Join Marnie Ward, Denver's favorite Chanteuse, as she intertwines lyrics with a double meaning to tickle your fancy! Teasing your brain with songs from the Great American Songbook to contemporary composers. Featuring drinks from Backyard Soda Company and local distillery! Must be 21+ to attend.

SATURDAY MAY 20

MODERN HOME TOURS: DENVER
11:00 - 5:00 pm
\$35 advance | \$40 day of

From attainability to sustainability, the singular thread that connects "Modern" is an outlook that embraces new possibilities in living and lifestyle. Through fun and informative tours in dozens of cities across the United States and Canada, as well as carefully cultivated examinations of the people, places and things that define "Modern," Modern Home Tours: Denver invites you into some of the most exciting examples of Modern architecture and design in the nation.

THURSDAY MAY 26

COLORADO CORKS & CUISINE
5:30 - 8:30 pm Four Mile Historic Park
\$35 members of Four Mile
\$45 non-member

Relish the fruits of local breweries, distilleries, wineries, and culinary artists while supporting Colorado history education. Proceeds from this event allow Four Mile to provide discounted or free field trips to underprivileged students in the Denver metro region. Sponsored by Rickenbaugh Automotive Group.

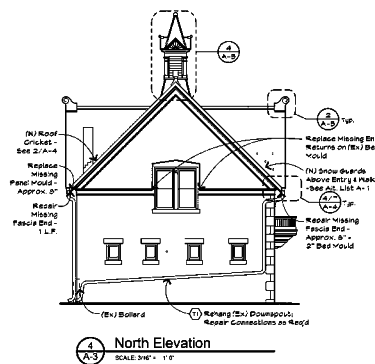

THURSDAY JUNE 9

"DENVER'S NEOCLASSICAL LANDMARKS" LECTURE BY TOM NOEL
6:00 pm
\$15 members of Historic Denver and ICAA
\$25 general public
L2 Church, 1477 Columbine Street

Join Dr. Tom Noel to discuss his latest book, "Denver Landmarks & Historic Districts," at this lecture, cosponsored by Historic Denver and Institute for Classical Architecture. Come celebrate Denver's greatest reflections of the glories that were Greece and the grandeur of Rome.



SATURDAY JUNE 11

MEET MOLLY BROWN TEA
11:00am, 1:00pm
\$24 Members & Children
\$26 Nonmembers
Molly Brown House Museum
1340 Pennsylvania Street

Enjoy this rare chance to take tea with "Molly Brown" as she recounts her Titanic experience and shares her passion for helping others. Margaret Brown turned those passions into proactive change in such areas as child welfare, historic preservation, and miner's rights. Suitable for ages 6 and up. Tickets available at www.mollybrown.org or by calling 303-832-4092 x16.

FRIDAY JULY 1

INDEPENDENCE CELEBRATION
Four Mile Historic Park
5:00-10:00 pm

Come celebrate with old-time games, historic demonstrations, live music, horse-drawn wagon rides, and more! Bring your blanket and stay to watch the Glendale fireworks show. Food trucks and a beer garden will be on site. Last entry to the Park is at 9:00 pm



THURSDAY JULY 21

JJ'S GENTLEMEN'S CLUB
6:00 - 8:00pm
\$26 Members | \$30 Nonmembers
Molly Brown House Museum
1340 Pennsylvania Street

When the Lady is away, the Gentleman will play! Margaret's out of town and J.J. is having some of you, his friends, over for an evening of gentlemanly pursuits. Cigars, cocktails, a few rounds of cards – what more can a Gentleman of J.J.'s stature want? Join the club! Ages 21+ only. Tickets available at www.mollybrown.org or by calling 303-832-4092 x17.

SATURDAY, AUGUST 6

THE AFTERLIFE OF MARGARET BROWN
— A GUIDED EXPLORATION OF THE
HAUNTINGS AT THE HOUSE OF LIONS

8:00 pm - 12:00 am
\$79 Admission | \$129 Admission + Intimate Spirit
Gallery Reading

What happens when the lights go out? Does Margaret Brown still inhabit this house? Join us on this cold, dark night as we welcome Chris Moon and Paulette "Mamma" Moon, along with Windy Lucero world-renowned psychic mediums and paranormal researchers, who will take us beyond the earthly realm. Discover what spirits inhabit the historic Molly Brown House during an intimate evening of paranormal investigation. Proceeds from this event will support the stewardship of Margaret's home and is sponsored by Capitol Hill Ghost Tours. Suitable for ages 16 and up.

Tickets available at www.mollybrown.org or by calling 303-832-4092 x16.



THIRSTY THURSDAYS

A YOUNG PROFESSIONALS GROUP

JUNE 16

QUEER IN THE AGE OF THE QUEEN

6:00 - 8:00pm \$15
Molly Brown House Museum, 1340 Pennsylvania Street

In an age viewed as ruled by repressed sexuality, take a look back at queer culture both here in the United States and abroad under the rule of Queen Victoria. Learn how the Queen herself spoke about sexuality, and how homosexual, transgender, and queer culture grew from this time.

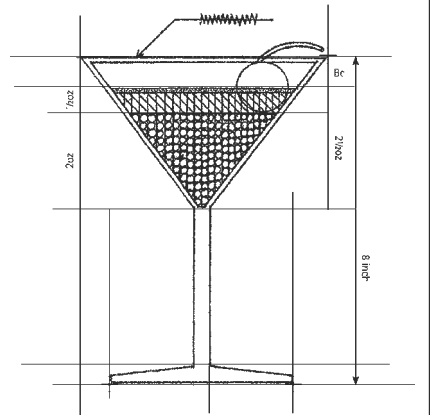

THE WOLFE GROUP
Fuller | Sotheby's
INTERNATIONAL REALTY

It's not about good luck, it's about **experience, intelligence** and relentless attention to detail. It's about matching our expertise to **your real estate goals**. Honored year after year, both locally and nationally, The Wolfe Group provides **RESULTS**.

"TOP 250" TEAM NATIONALLY | "TOP 3" TEAM 2000-2012 | "TOP 5" TEAM IN COLORADO
-Real Trends & The Wall Street Journal | -Denver Board of Realtors® | -Real Trends Best Agents in America

www.WOLFGROUPDENVER.COM